

32.yıl

ADIMIZ KALİTEMİZ

BAŞAKCI LASTİK

Garaj servis ekipmanları, lastik tamir makina ve malzemeleri ticareti, hırdavatçılık yapmaktadır.

32 yıllık tecrübe birikimi Ali BAŞAKCI'nın liderliğinde hizmet vermeye başlamıştır.

Öncelikli hedefimiz yalnızca kaliteli ürün değil, kaliteli hizmet de sunarak müşterilerimizin mutlak memnuniyetini sağlamaktır.

Firmamız, her zaman teknolojiyi en yakından takip edip, sürekli gelişirken, kalitesinden ödün vermemeyi prensip edinmiştir.

Kalitemizden ödün vermeyip Türk Sermayesini de koruyarak değerli müşterilerimize hizmet vermeyi amaç edinmiş bulunmaktayız.

Başakcı Lastik ailesi olarak Yurt İçi ve Yurt Dışına kaliteli ürünlerimizi pazarlamaktayız.

Siz değerli dostlarımızın güveni ve desteği bizleri her zaman daha iyi olmaya teşvik eder.

"Adımız Kalitemiz" altındaki sloganımızın açılımı dürüstlük, güven ve kaliteyi simgeler.

Siz değerli dostlarımıza sonsuz sevgi ve saygı çerçevesinde teşekkürlerimizi sunmaktan büyük onur duyuyoruz.

Başakcı Lastik



Sektörün en önde gelen firmalarıyla çalışarak, gücümüze güç katıyoruz



İÇİNDEKİLER

LASTİK SÖKME TAKMA MAKİNALARI	5-11
ROT BALANS MAKİNALARI	12-14
NİTROJEN MAKİNALARI	15
JANT DÜZELTME MAKİNALARI	16
LİFTLER	17
KOMPRESÖRLER	18-21
KRİKOLAR	22-26
YIKAMA MAKİNALARI	26-29
YAĞLAMA MAKİNALARI	30-32
TAŞLAMA MOTORLARI VE TAŞLARI	33
MENGENE - İŞKENCE	33
HAVALI ALETLER	34-37
İÇ VE DIŞ LASTİKLER	38-41
BAŞAKCI TEAM YAMALAR	42-43
LASTİK TAMİR MALZEMELERİ	44-48
EL ALETLERİ	49-54
AKÜ SARJ - TEST CİHAZLARI	55-59
İŞ GÜVENLİĞİ	59
KAR ZİNCİRİ	60
DİĞER	60



BAŞAKCI LASTİK[®]
YARDIMCI MALZEMELERİ ve GARAJ EKİPMANLARI TİC.

BAŞAKCI[®]
TEAM
TYRE EQUIPMENTS

*Tedarik zincirimiz
Türkiye'nin
4 bir yanına ulaşıyor*



LASTİK SÖKME TAKMA MAKİNALARI

BİNEK GRUPLAR

S-300



JANT KAPASİTESİ: 10"-18" veya
10"-24"
MAX LASTİK ÇAPI: 970 mm (38")
YANAK DÜŞÜRME KUVVETİ: 2500 kg
ÇALIŞMA BASINCI: 8-10 Bar
MOTOR GÜCÜ: 0,75 Kw-1,0 Hp

S-400



JANT KAPASİTESİ: 10"-18" veya
10"-24"
MAX LASTİK ÇAPI: 970 mm (38")
YANAK DÜŞÜRME KUVVETİ: 2500 kg
ÇALIŞMA BASINCI: 8-10 Bar
MOTOR GÜCÜ: 0,75 Kw-1,0 Hp

S-500



JANT KAPASİTESİ: 10"-18" veya
10"-24"
MAX LASTİK ÇAPI: 1100 mm (43")
YANAK DÜŞÜRME KUVVETİ: 2500 kg
ÇALIŞMA BASINCI: 8-10 Bar
MOTOR GÜCÜ: 0,75 Kw-1,0 Hp

COCKER ROBOTEX



JANT KAPASİTESİ: 10"-24"
MAX LASTİK ÇAPI: 1130 mm (44")
YANAK DÜŞÜRME KUVVETİ: 2500 kg
ÇALIŞMA BASINCI: 8-10 Bar
MOTOR GÜCÜ: 0,75 Kw-1,0 Hp
*Monofaze Motor Seçeneği Mevcuttur

RIVIERA 10"-22"



İÇTEN SIKIŞTIRMA: 12"-22"
DIŞTAN SIKIŞTIRMA: 10"-20"
YANAK DÜŞÜRME KUVVETİ: 2500 kg
OPSİYONEL ŞOKLAMA SİSTEMİ
MAKS. 11.5" LASTİK GENİŞLİĞİ

CARUZO 12"-26"



STANDART DAMAK DÜŞÜRME EL
KONTROL BUTONU
LASTİK MAKARALARI

BAŞAKCI[®]
TEAM
TYRE EQUIPMENTS

BİNEK GRUPLAR

ZANINI 10"-22"

İÇTEN SIKIŞTIRMA:12"-24"
DIŞTAN SIKIŞTIRMA:10"-22"
YANAK DÜŞÜRME KUVVETİ: 2500 kg
OPSİYONEL ŞOKLAMA SİSTEMİ
MAKS. 12" LASTİK GENİŞLİĞİ



BRAVA MAXI 12"-26"

İÇTEN SIKIŞTIRMA:14"-26"
DIŞTAN SIKIŞTIRMA:12"-24"
YANAK DÜŞÜRME KUVVETİ: 2500 kg
OPSİYONEL YÜKSEK PERFORMANSLI
OPSİYONEL ŞOKLAMA SİSTEMİ
MAKS. 15" LASTİK GENİŞLİĞİ



LST 19

ÇALIŞMA BASINCI: 8 -10 Bar
GÜÇ: 0,75 - 1,5 Hp
DAMAK DÜŞÜRME KUVVETİ: 2500 kg
MOTOR: 380/220V
MOTOR GÜCÜ: 1.1KW/1.5HP/1500
D/d
TABLA YÜKSEKLİĞİ : 760mm
AĞIRLIK: 198 kg



LST 22

ÇALIŞMA BASINCI: 8 -10 Bar
GÜÇ: 0,75 - 1,5 Hp
DAMAK DÜŞÜRME KUVVETİ: 2500 kg
CALISMA VOLTAJI:
380V/3PHASE/50HZ
220V SINGLE-PHASE
MOTOR GÜCÜ: 1.1KW/1.5HP/1500
RPM
TABLA YÜKSEKLİĞİ : 780mm MAX
TEKERLEK ÇAPI : 1000mm
TEKERLEK GENİŞLİĞİ: 3"-12"
AĞIRLIK: 245Kg



ZANITRO N2 10"-20"

TEK NİTROJEN MEMBRANI,NİTROJEN
ÜRETİMİ :1000 LT/SAAT-8BAR
ÇALIŞMA BASINCI: 8-10 BAR,ÇİFT
HAVA KURUTUCULU İLE UZUN
ÇALIŞMA ÖMRÜ
25 LT HAVA TÜPÜ,HEM NİTROJEN
HEM HAVA BASABİLME ÖZELLİĞİ
LASTİK BASINCI GÖSTEREN
BÜYÜK HAVA SAATI
FAZLA HAVAYI
TAHLİYE ETME BUTONU



TECHNOROLLER XL

ÇALIŞMA BASINCI: 8 -10 Bar
GÜÇ: 0,75 - 1,5 Hp
MAKSİMUM TEKERLEK ÇAPI: 1000 mm
İÇTEN SIKIŞTIRMA: 12"-29"
DIŞTAN SIKIŞTIRMA: 10"-26"
MAKSİMUM TEKERLEK GENİŞLİĞİ: 14"
DAMAK DÜŞÜRME KUVVETİ: 10000 kg



CARUZO-8000

12-26" OTOMATİK DAMAK DÜŞÜRME
EL KONTROL BUTONU



HOFMAN 501 RACING

10"-24" (22" EXTERNAL)
1000 MM
13"
2500 KG
10 BAR (145 PSI)
3PH: 230-400V/50HZ/550W
1PH: 230V/50HZ/750W
290 KG



PIKOLA PLUS

İÇTEN SIKIŞTIRMA:12"-22"
DIŞTAN SIKIŞTIRMA:10"-20"
YANAK DÜŞÜRME KUVVETİ: 2500 kg
STANDART YÜKSEK PERFORMANSLI
LASTİKLER İÇİN PLUS SİSTEM
MAKS. 11,5" LASTİK GENİŞLİĞİ



RIVIERA TI PLUS

İÇTEN SIKIŞTIRMA:12"-22"
DIŞTAN SIKIŞTIRMA:10"-20"
YANAK DÜŞÜRME KUVVETİ: 2500 kg
STANDART ŞOKLAMA SİSTEMİ
MAKS. 11" LASTİK GENİŞLİĞİ



HOFMAN 501

CLAMPING ADJUSTABLE (OUTSIDE /
INSIDE IN INCH):
10-20/12-22 OR 11-21/13-23
(STANDARD) OR 12-22/14-24
MAXIMUM RIM WIDTH 13 INCHES
MAXIMUM TYRE DIAMETER 1000 MM
OPERATING PRESSURE LIMITING
DEVICE 10 BAR
INFLATING PRESSURE LIMITING
DEVICE 3,5 BAR (CE)



PIKOLA PLUS

20-22" PLUS APARATLI



BİNEK GRUPLAR

MEGAMONT 301

2 CLAMPING-CYLINDERS
RIM CLAMPING INSIDE 12 - 24 INCHES,
OUTSIDE 10 - 22 INCHES
MAXIMUM RIM WIDTH 13 INCHES
MAXIMUM TYRE DIAMETER 1000 MM
OPERATING PRESSURE LIMITING
DEVICE 10 BAR
INFLATING PRESSURE LIMITING
DEVICE 3,5 BAR (CE)



301 RACING

10"-24" (22" EXTERNAL)
1000 MM 13"
2500 KG
10 BAR (145 PSI)
3PH: 230-400V/50HZ/550W
1PH: 230V/50HZ/750W
260 KG



MEGAMONT 701

RIM CLAMPING INSIDE 12-26
INCHES, OUTSIDE 10-24 INCHES
MAXIMUM RIM WIDTH 15 INCHES
MAXIMUM TYRE DIAMETER 1000 MM
10 BAR OPERATING PRESSURE REG-
ULATOR WITH MANOMETER
AND WATER SEPARATOR
INFLATING PRESSURE LIMITING
DEVICE 3,5 BAR (CE)



MEGAMONT 601

CLAMPING ADJUSTABLE (OUTSIDE/
INSIDE IN INCH):
10-20/12-22 OR 11-21/13-23
(STANDARD) OR 12-22/14-24
MAXIMUM RIM WIDTH 15 INCHES
MAXIMUM TYRE DIAMETER 1000 MM
FILTER WITH PRESSURE REGULATOR
AND MANOMETER FOR 10 BAR
WORKING PRESSURE



601 RACING

İÇTEN SIKIŞTIRMA:12"-22"
DIŞTAN SIKIŞTIRMA:10"-20"
YANAK DÜŞÜRME KUVVETİ: 2500 kg
OPSİYONEL ŞOKLAMA SİSTEMİ
MAKS. 11.5" LASTİK GENİŞLİĞİ



YEDEK PARÇA



KAMYON VE İŞ MAKİNALARI GRUPLARI

BAŞAKÇI HST-2002

HİDROLİK
4 ÇENELİ KAVRAMA SİSTEMİ
KALİTELİ MEKANİK SİSTEM VE RAKİ-
PLERİNDEN FARKLI KUVVETLİ KIZIL
YATAKLAMALAR
KIZIL MALZEMEDEN İMAL EDİLEN
REDÜKTÖR DİŞLİSİ
KİTLEMELİ SÖKME-TAKMA KOLU
UZAKTAN KUMANDALI
ELEKTRİK KAÇAKLARINA KARŞI
DEVRE KESİCİ SİSTEM

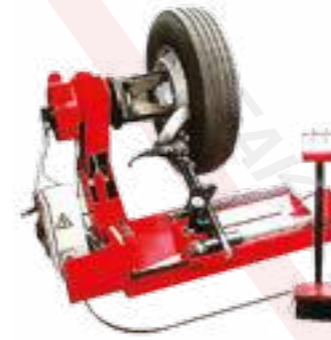

SPEEDY 14-56

14"-56" JANT ARASI
AĞIR VASITALAR VE
İŞ MAKİNALARI İÇİN
FULL OTOMATİK LASTİK SÖKME
TAKMA MAKİNASI
STANDART UZAKTAN KUMANDA

ALLEGRO 14-26

KAMYONLAR İÇİN FULL OTOMATİK
LASTİK SÖKME TAKMA MAKİNASI
OPSİYONEL UZAKTAN KUMANDA
MAX.LASTİK TAŞIMA AĞIRLIĞI
1000 KG.
NET AĞIRLIK 563 KG



SWING 14"-30'

14"-30" KAMYON JANTLARI İÇİN
OPSİYONEL UZAKTAN KUMANDALI

ALLEGRO ECO 14"-26"

ALLEGRO ECO 14"-26"
14"-26"
FULL AUTOMATIC TYRE CHANGERS
FOR TRUCK
OPTIONAL REMOTE CONTROL
MAX. TYRE LIFTING
CAPACITY 1000 KG
NET WEIGHT: 530 KG



LEON 2600S

MAX. LASTİK ÇAP: 1625MM (64")
MAX. LASTİK GENİŞLİĞİ: 762MM (30")
MAX. LASTİK AĞIRLIĞI: 1750KG
MAX.TORK: 1500NM
JANT MERKEZLEME
KAPASİTESİ:14"-28"
TOPUK DÜŞÜRME GÜCÜ: 27KN
ÇALIŞMA BASINCI: 120-150 BAR
MOTOR GÜCÜ: 380VOLT
2.2 KW - 3HP
HİDROLİK MOTOR GÜCÜ: 380VOLT -1.5
KW - 2HP
EN BOY YÜKSEKLİK: 1470X1800X750MM
AĞIRLIK: 730KG

LEON-5600S

MAX. LASTİK ÇAP: 2300 MM [90"]
MAX. LASTİK GENİŞLİĞİ: 1065 MM [42"]
MAX. LASTİK AĞIRLIĞI: 1500 KG (3810LBS)
DAMAK DÜŞÜRME GÜCÜ: 2700 KG
(6860LBS)
MİNİMUM JANT BAĞLAMA ÇAP: 14" MAX.
JANT ÇAP: 56"
ÇALIŞMA BASINCI: 110 BAR
HİDROLİK ÜNİTE MOTORU: 1,5 KW - 2HP /
1400RPM 230 / 400 V 3PH - [24 V]
DİŞLİ KUTUSU: (MOTOR) 1,3 - 1,8KW / 1,7-
2,4HP / 1400 / 2800 RPM
AĞIRLIK: 860 KG
EN - BOY - YÜKSEKLİK: 1720 X 1910-2257
X 866-1540 MM
SANDIK ÖLÇÜLERİ 2150 X 2800 X 1100MM



ZİRVE 30

YARI OTOMATİK TİCARİ ARAÇ
KAMYON-OTOBÜS LASTİKLERİ İÇİN
DÜŞÜK VOLTAJLI TAKILABİLİR KON-
TROL PANELİ İLE ELEKTROHİDROLİK
OLARAK KUMANDA EDİLEBİLİR.
OPSİYONEL ÇİFT DEVİR ÖZELLİKLİDİR

KAMYON VE İŞ MAKİNALARI GRUPLARI

ALLEGRO MOBİL 14"-26"

GEZİCİ SERVİS ARAÇLARI İÇİN
FULL OTOMATİK KAMYON LASTİK SÖKME TAKMA MAKİNASI
OPSİYONEL UZAKTAN KUMANDA
MAKS.LASTİK TAŞIMA AĞIRLIĞI 700 KG.
NET AĞIRLIK 450 KG



ZİRVE 56 DS

ZİRVE 56 DS KAMYON LASTİK SÖKME
TAKMA MAKİNASI
MAKS. TEKERLEK GENİŞLİĞİ: 960 MM
MAX. TEKERLEK ÇAP: 2480 MM
MAX. TEKERLEK AĞIRLIĞI: 2500 KG
AĞIRLIK: 870 KG
DÖNÜŞ HIZI: 7-14 D/DK
DAMAK DÜŞÜRME HIZI: 2000-2500 KG
VOLTAJ: 380 V - 3 FAZ
JANT TUTMA KAPASİTESİ: 14"-56"
POMPA MOTORU: 1,5 KW
ŞANZİMAN MOTORU: 2,2 KW
ÇALIŞMA BASINCI: 0-200 BAR (STANDART
180 BAR)



MEGAMOUNT 351

TYRE CHANGER FOR TRUCKS AND
BUSSES WITH TUBELESS TYRES
CLAMPING RANGE 14 - 26 INCHES
TYRE WIDTH MAXIMUM 780 MM
TYRE DIAMETER MAXIMUM 1200 MM



MEGAMOUNT 551

MEGAMOUNT 551 OTOMATİK LASTİK
SÖKME TAKMA MAKİNESİ
DOUBLE MOUNTING AND
DEMOUNTING TOOL TO OPERATE
WITH TUBE AND TUBELESS TYRES
RIGHT AND LEFT HAND SPIN
2-SPEED CHUCK ROTATING SYSTEM
CLAMPING RANGE 13-27 INCHES
TYRE WIDTH MAXIMAL 780 MM
TYRE DIAMETER MAXIMAL 1600 MM



BAŞAKCI-TRAKTÖR ATTIRMA

BAŞAKCI TRAKTÖR LASTİĞİ SÖKME
MAKİNASI
POMPA BASKI KUVVETİ: 2100 KG
ÇALIŞMA BASINCI: 10-12 BAR
UZUNLUK: 1350 MM
MAX. GENİŞLİK: 900 MM
MAX. YÜKSEKLİK: 950 MM



KAMYON LEVYE SETİ-TUBELESS



BAŞAK MEKANİK YANAK DÜŞÜRME MAK.

AĞIR VASITA GRUBU ARAÇLAR İÇİN
YANAK DÜŞÜRME MAKİNASI
YOL SEVİYESİNDE KULLANIMA UY-
GUN ÖZEL TIRNAKLARI SAYESİNDE
JANTI ÇİZMEDEN



TRAKDAM HAVALI YANAK DÜŞÜRME MAK.

AĞIR VASITA GRUBU ARAÇLAR İÇİN
YANAK DÜŞÜRME MAKİNASI



ŞOKLAMA TÜPLERİ, DİŞ AÇMA, YANAK AÇMA VS

SPEED AIR - ŞOKLAMA TÜPÜ

ÇALIŞMA BASINCI: 8 BAR
ŞOKLAMA GÜCÜ: 180 BAR



BAŞAKCI LASTİK

HAVALI LASTİĞİ JANTTAN AYIRMA
MAKİNESİ



BAŞAKCI DİŞ AÇMA MAK.

LASTİK DİŞ AÇMA MAKİNESİ



HAVALI LASTİK AÇMA MAK.

8-10 BAR ÇALIŞMA BASINCI
IŞIKLI AYDINLATMA
KOLAY VE HIZLI KULLANIM



DİŞ LASTİK KAYNAK MAK. TERMOSTATLI

BASKI KUVVETİ: 10KN
TERMOSTAT: 300 C OTOMATİK
ÇALIŞMA BASINCI: 8-10 BAR
YÜKSEKLİK: 1250 MM
DERİNLİK: 350 MM
GENİŞLİK: 180 MM
3 ADET KALIP VE ÜTÜLÜ



MULTI

YÜKSEKLİK: MIN.360MM,
MAX.780MM
DARBE KUVVETİ: 71KPM
STANDART 3 ADET 1" LOKMA



PNÖMATİK LASTİK YANAK AÇICI

8-10 BAR ÇALIŞMA BASINCI
IŞIKLI AYDINLATMA
KOLAY VE HIZLI KULLANIM



İÇ LASTİK KAYNAK MAKİNASI

BASKI KUVVETİ: 650-1150 KG
TERMOSTAT: 300-500 C OTOMATİK
ÇALIŞMA BASINCI: 8-12 BAR
YÜKSEKLİK: 1250 MM
DERİNLİK: 350 MM
GENİŞLİK: 180 MM
İÇ LASTİKLERİN SICAK YAMASINDA
KULLANILAN TERMOSTATLI MAK-
İNADIR. AYAK PEDALLI KUMANDA
PNÖMATİK BASKI



SABİT BALANS

HOFMAN MS800

JANT GENİŞLİĞİ: 1,5" TO 20"
JANT ÇAP: 10" TO 30" MAX.
ÇAP: 1067 MM MAX.
GENİŞLİK: 530 MM MAX.
AĞIRLIK: 75 KG
HIZ: 180 RPM 220 V / 500 W



HOFMAN MS1000

JANT WIDTH: 1,5" TO 20"
JANT ÇAP: 10" TO 30" MAX.
ÇAP: 1067 MM MAX.
GENİŞLİK: 530 MM MAX.
AĞIRLIK: 75 KG
HIZ: 100 U/MIN 220 V / 500 W



HOFMAN MS2000

ÇELİK JANTLAR İÇİN TAM OTOMATİK
LAZERLİ VERİ GİRİŞLİ DOKUNMATİK
EKRANLI



BM 5500

JANT BOYUT: 10" - 22"
TEKERLEK ÇAP: 60 KADAR KG
MOTOR: 220V
DENGELEME HIZ: 160 D / M
AĞIRLIK: 95 KG
MONİTÖR: TV TUNER İLE 17" LCD DÜZ
EKRAN VİDEO
BİLGİSAYAR: ELEKTRONİK
RENKLİ MONİTÖR
TEKERLEK HER İKİ UÇAKLARIN
GÖZLEMİ (EXPERIOR/İÇ)
TEK DÖNÜŞ İLE DİNAMİK
DENGELEME
HIZLI VE DOĞRU DENGELEME



BM 5500 INFINITY

İÇ - DIŞ ÖLÇÜM YAPABİLME
JANT BOYUT: 10" - 22"
TEKERLEK ÇAP: 60 KADAR KG
MOTOR: 220V
DENGELEME HIZ: 160 D / M
AĞIRLIK: 95 KG
MONİTÖR: TV TUNER İLE 17" LCD DÜZ
EKRAN VİDEO
BİLGİSAYAR: ELEKTRONİK
RENKLİ MONİTÖR
TEKERLEK HER İKİ UÇAKLARIN
GÖZLEMİ (EXPERIOR/İÇ)
TEK DÖNÜŞ İLE DİNAMİK
DENGELEME
HIZLI VE DOĞRU DENGELEME



SIRION LX

HASSASİYET: 1GR
ÖLÇÜM ZAMANI: 6 SN
MAX TEKERLEK AĞIRLIĞI: 65KG
MAX JANT ÇAP: 24(INCH)
JANT GENİŞLİĞİ: 1,5-20(INCH)
GÜÇ KAYNAĞI: 220V, 1PH, 50HZ
DÖNÜŞ HIZI: 100 RPM



SIRION PRO

24" LCD EKRANLI.
ÇOK FONKSİYONLU SEMBOLLER VE TUŞ
TAKIMI SAYESİNDE KOLAY KULLANIM.
DAVLUMBAZ KONTROLLÜ OTOMATİK
START.
BALANSSIZLIK POZİSYONUNDA OTOMATİK
HAVALI FRENLEME.
LASER İLE İÇ YÜZEY BALANSSIZLIK NOK-
TASI İŞARETLEMESİ (ÇAKMA-YAPIŞTIRMA)
LASER İLE DIŞ YÜZEY BALANSSIZLIK NOK-
TASI İŞARETLEMESİ (YAPIŞTIRMA)
DÖNÜŞ SONRASI JANT DIŞ YÜZEY
BALANSSIZLIK NOKTASI OTOMATİK PO-
ZİSYONLAMA.
TEK TUŞ İLE İÇ YÜZEY BALANSSIZLIK NOK-
TASI OTOMATİK POZİSYONLAMA.
UZAKLIK-ÇAP OTOMATİK BİLGİ GİRİŞİ.
SONAR SİSTEMLİ OTOMATİK GENİŞLİK
ÖLÇÜMÜ (SIRION PRO/S)



SIRION TRUCK

24" LCD EKRANLI.
ÇOK FONKSİYONLU SEMBOLLER VE TUŞ
TAKIMI SAYESİNDE KOLAY KULLANIM.
DAVLUMBAZ KONTROLLÜ
OTOMATİK START.
BALANSSIZLIK POZİSYONUNDA OTOMATİK
HAVALI FRENLEME.
DÖNÜŞ SONRASI JANT DIŞ YÜZEY
BALANSSIZLIK NOKTASI OTOMATİK PO-
ZİSYONLAMA.
TEK TUŞ İLE İÇ YÜZEY BALANSSIZLIK NOK-
TASI OTOMATİK POZİSYONLAMA.
UZAKLIK-ÇAP OTOMATİK BİLGİ GİRİŞİ.
KENDİ KENDİNE KALİBRASYON.
ALÜMİNYUM JANTLAR İÇİN ÖZEL ALU/
ALU-S/ALU-S1 PROGRAMLARI.
ÇOK KOLLU ALÜMİNYUM JANTLAR İÇİN
ÖZEL OLARAK GELİŞTİRİLMİŞ KURŞUN
BÖLME VE JANT KOLLARI ARKASINA
GİZLEME PROGRAMI.



SIRION ECO

HASSASİYET: 1GR
ÖLÇÜM ZAMANI: 8 SN
MAX TEKERLEK AĞIRLIĞI: 8 SN
MAX JANT ÇAP: 24(INCH)
JANT GENİŞLİĞİ: 1,5-20(INCH)
GÜÇ KAYNAĞI: 220V, 1PH, 50HZ
DÖNÜŞ HIZI: 200 RPM



SIRION

HASSASİYET: 1 GR
ÖLÇÜM ZAMANI: 8 SN
MAX TEKERLEK AĞIRLIĞI: 60 KG
MAX JANT ÇAP: 24(INCH)
JANT GENİŞLİĞİ: 1,5-20(INCH)
GÜÇ KAYNAĞI: 220V, 1PH, 50HZ
DÖNÜŞ HIZI: 200 RPM



SEYYAR BALANS

R 33

DİJİTAL GÖSTERGE
STROBOSKOPİK IŞIK SİSTEMİ
HEM BİNEK HEM AĞIR VASİTA GRU-
BUNA HİZMET VEREBİLME
TEK DÖNÜŞTE HASSAS BALANS
İŞLEMİ
KAMYON OTOBÜS
SEHPA KAPASİTESİ: 5.000KG
BİNEK
SEHPA KAPASİTESİ: 800KG
MOTOR: 380V, 3PH, 50HZ, 5,5HP



SL 2000

SL 2000 SEYYAR BALANS MAKİNESİ . ÇİFT
TRİPOT İLE BİNEK VE AĞIR VASİTA GRU-
P ARAÇLARINA BALANS YAPABİLME, ARAÇ
ÜZERİNDE BALANS İMKANI, HASSAS
BÜYÜK KASNAK, GÜÇLÜ FLAŞ IŞIK, KABLO
SARMA MEKANİZMASI VE EL TUTACAĞI



ROT BALANS MAKİNALARI

BALANS KURŞUNLARI

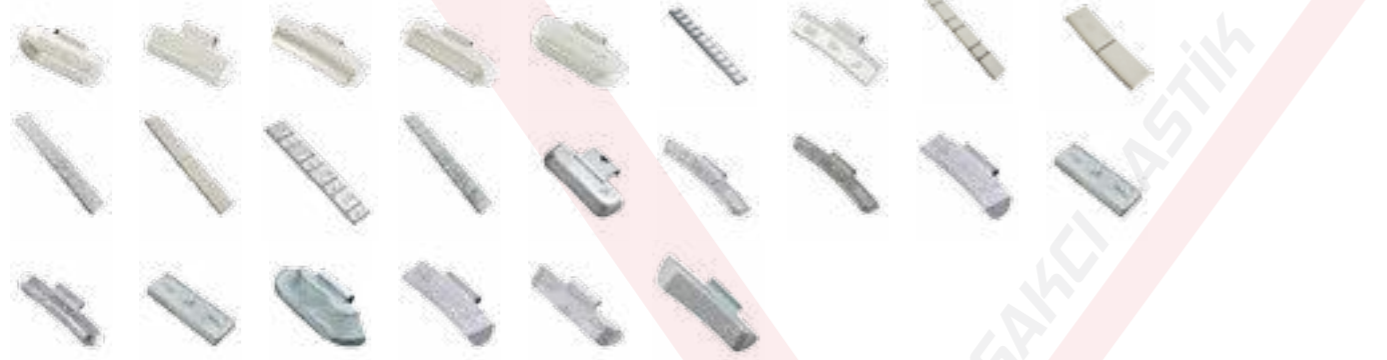

STANDART JANT	ALÜMİNYUM JANT	RENAULT ALM.JANT	K.TUBLES JANT	K.TUBLES YAPIŞTIRMA	KAMYON	KAMYONET	ŞERİT(NORMAL) YAPIŞTIRMA 5MM	ŞERİT(GENİŞ) YAPIŞTIRMA 4 MM
05gr	05gr	05gr	50gr	50gr	100gr	28gr	60gr	60gr
10gr	10gr	10gr	75gr	75gr	150gr	56gr		
15gr	15gr	15gr	100gr	100gr	200gr	85gr		
20gr	20gr	20gr	150gr	125gr	250gr	113gr		
25gr	25gr	25gr	200gr	150gr	300gr	140gr		
30gr	30gr	30gr	250gr	175gr	350gr	170gr		
35gr	35gr	35gr	300gr	200gr	400gr			
40gr	40gr	40gr		250gr				
45gr	45gr			300gr				
50gr	50gr							
55gr	55gr							
60gr	60gr							
70gr								
80gr								
90gr								
100gr								

FAR AYAR CİHAZLARI



HBA-25

ELEKTRONİK KONTROL ÜNİTELİ
PROFESYONEL FAR AYAR CİHAZI
TÜM FAR TİPLERİ İÇİN (XENON,
BIXENON VS.) KULLANIM İMKANI
LAZER VİZÖR
LAZER POINTER
TEST RAPORU YAZICI ÇIKTISI
BİLGİSAYARA BAĞLANABİLME
ÖZELLİĞİ (İSTEĞE BAĞLI)
ELEKTRONİK PROFESYONEL FAR
AYAR CİHAZI



FA-50

PLEXIGLASS LENS
DİJİTAL LÜKSMETRE
TERAZI
AYAR AYNASI



FA-100

PLEXIGLASS LENS
DİJİTAL LÜKSMETRE
TERAZI
AYAR AYNASI

NİTROJEN MAKİNALARI

FS-6000



2 YIL GARANTİ

UYGULAMA ARAÇLARI : MOTORSİKLETLER, ARABALAR,
KAMYONETLER, MINİBÜSLER
GÜÇ KAYNAĞI : 220V 50HZ
GÜÇ SARFIYATI : 40 WATT
NİTROJEN SAFLIĞI : 99.5%
GİRİŞ HAVA BASINCI : 110-145PSI(8-10 BAR)
ÇIKIŞ NİTROJEN BASINCI : 58-87PSI(4-7 BAR)
NİTROJEN ÜRETME HIZI : 4000-6000 L/H
ÇALIŞMA SICAKLIĞI : -18-+40 C
ÖLÇÜM ARALIĞI : 5-150PSI (0.4-9.99 KG/CM2)
MAX BASINÇ : >150PSI (>10 KG/CM2)
HASSASİYET : ±1%+0.5PSI
EKRAN : 11,5" DİJİTAL GÖSTERGE
EBATLAR : 1400x880x580(MM)
VAKUM : ELEKTRİK KONTROLLU VAKUM CİHAZI
120LT. NİTROJEN DEPOLAMA TANKI
10M. YÜKSEK BASINÇ HAVA HORTUMU

FS-3500



2 YIL GARANTİ

UYGULAMA ARAÇLARI : MOTORSİKLETLER, ARABALAR,
KAMYONETLER, MINİBÜSLER
GÜÇ KAYNAĞI : 220V 50HZ
GÜÇ SARFIYATI : 20 WATT
NİTROJEN SAFLIĞI : 99.5%
GİRİŞ HAVA BASINCI : 110-145PSI(8-10 BAR)
ÇIKIŞ NİTROJEN BASINCI : 58-87PSI(4-7 BAR)
NİTROJEN ÜRETME HIZI : 2500-4000 L/H
ÇALIŞMA SICAKLIĞI : -18-+40 C
ÖLÇÜM ARALIĞI : 5-150PSI(0.4-9.99 KG/CM2)
MAX BASINÇ : >150PSI (>10 KG/CM2)
HASSASİYET : ±1%+0.5PSI
EKRAN : LED DİJİTAL GÖSTERGE
EBATLAR : 1430x730x550(MM)
VAKUM : TAŞINABİLİR VAKUM CİHAZI
70LT. NİTROJEN DEPOLAMA TANKI
12M. YÜKSEK BASINÇ HAVA HORTUMU

FS-4000



2 YIL GARANTİ

UYGULAMA ARAÇLARI : MOTORSİKLETLER, ARABALAR,
KAMYONETLER, MINİBÜSLER
GÜÇ KAYNAĞI : 220V 50HZ
GÜÇ SARFIYATI : 60 WATT
NİTROJEN SAFLIĞI : 99.5%
GİRİŞ HAVA BASINCI : 110-145PSI(8-10 BAR)
ÇIKIŞ NİTROJEN BASINCI : 58-100PSI(4-7 BAR)
NİTROJEN ÜRETME HIZI : 2000-4000L/H
ÇALIŞMA SICAKLIĞI : -20-+70 C
ÖLÇÜM ARALIĞI : 5-145PSI(0.4-9.99
KG/CM2)
MAKSİMUM BASINÇ : >145PSI(>10
KG/CM2)
HASSASİYET : ±1%+0.5PSI
EKRAN : 11" DİJİTAL GÖSTERGE
EBATLAR : 1400x600x520(MM)
NET AĞIRLIK : 130 KG
VAKUM : TAŞINABİLİR VAKUM CİHAZI
70LT. NİTROJEN DEPOLAMA TANKI
10M. YÜKSEK BASINÇ HAVA HORTUMU

KÖNİG JUMBO

KÖNİG JUMBO K
JANT ÖLÇÜSÜ: 10"-24"
STANDART KÖPRÜLÜ DAYAMA KITI
REDÜKTÖRLÜ
KAYAR TIP TORNALI



JUNIOR

KÖNİG JUNIOR 10-18
Jant ölçüsü :10"-24"
Standart büyük dayama kiti
Tornasız
Motorsuz



EPL-2000

EPL 2000 BASINÇLI HAVA İLE ÇALIŞIR.
12 BAR BASINÇTA 3000 KG KALDIRMA
KAPASİTESİ
EPL 2000 HORTUM PATLAMASI
DURUMUNDA DEVREYE GİREN
EMNİYET SİSTEMİ İLE DONATILMIŞTIR-
PEDAL KONTROL SİSTEMİ SAYESİNDE
İSTENİLEN YÜKSEKLİKTE ÇALIŞILABİLİR
BALANS İŞLEMLERİNİN
RAHAT YAPILABİLMESİ İÇİN RAMPALAR
KAYMA ÖZELLİĞİNE SAHIPTIR
EPL 2000 4 ADET KAUCUK KALDIRMA
TAKOZU MEVCUTTUR. (120X160X80MM)
OPSİYONEL ÖZELLİKLERİ
DAHA GENİŞ ARAÇLAR İÇİN 4 ADET
AYARLANABİLİR KALDIRMA KOL SİSTEMİ.
TEKNİK ÖZELLİKLERİ
ÇALIŞMA BASINCI: 8 -12 BAR
AĞIRLIK: 320KG
EN:1375MM
BOY: 2280MM

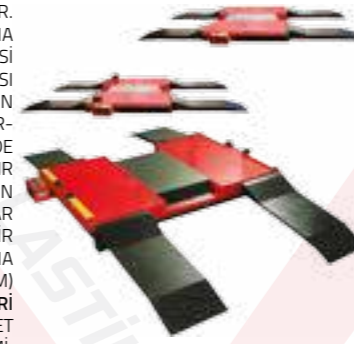

ASL-2500

MOTOR: 380/220 WOLT
MOTOR GÜCÜ: 4KW/5.5HP/1500 D/D
KALDIRMA KAPASİTESİ: 3200KG
KALDIRMA YÜKSEKLİĞİ: 1940MM
YAĞLAMA SİSTEMİ: AUTOMATIC
KALDIRMA SÜRESİ: 60SN
AĞIRLIK: 750KG



KÖNİG

KÖNİG 5400 10-24
JANT ÖLÇÜSÜ: 10"-24"
STANDART BÜYÜK DAYAMA KITI
KASNAKLI
KAYAR TIP TORNALI

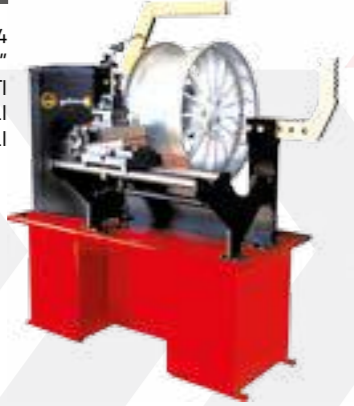

MASTER

MASTER 10"-30" 75 OÖCE
GÜÇLENDİRİLMİŞ YENİ
PİSTONLAR,
HİDROLİK YARDIMCI DAYAMA KOLU,
DERİN ŞEKİLLİ BASKI ÇENESİ
ÖZELLİĞİ İLE AYNI NOKTADAN
JANTIN HEM İÇİNE HEM DIŞINA
BASKI YAPABİLME ÖZELLİĞİ



BM-3200

KALDIRMA KAPASİTESİ: 3200KG
MINİMUM YÜKSEKLİK: 900MM
MAKSİMUM YÜKSEKLİK: 950MM



RECEPTION

RESEPSİYONLU LİFT



PROFESSIONAL

PROFESSIONAL DIGITAL 5600CE
JANT ÖLÇÜSÜ 10"-26"
KAYAR TIP TORNALI
REDÜKTÖRLÜ
ÇOK YÖNLÜ JOYSTİK
ELEKTRONİK HIZ KONTROL
YÜKSEK HASSASİYETLİ DİJİTAL
ÖLÇÜM SİSTEMİ



ROLLER MAXİ

ROLLER MAXİ 78D 00
BİNEK JANTLAR İÇİN,
ALAŞIM VE DEMİR JANTLAR İÇİN
ROLLER MAXİ
JANTIN İKİ TARAFINI AYNI ANDA
DÜZELTME ÖZELLİĞİ,
FAKLI KALINLIKLARDAKİ JANTLARA
UYUMLULUK,
GÜÇLÜ KIZAK SİSTEMİ İLE RİJİT
DÜZELTME,
KALINLIĞI 3 MM YE KADAR OLAN
TÜM SAC JANTLARA UYUMLUDUR.



YEDEK PARÇA



TRANSPALET



LUPAMAT TEK KADEMELİ KOMPRESÖRLER

ÜRÜN KODU	BASINÇ (BAR)	PISTON DEPLASMANI (LT/DK)	MOTOR GÜCÜ (HP)	DEPO HACMİ(LT)
LKD 51-300	8	200	1,5	100
LKD 51/300 M Mono	8	200	1,5	100
LKD 61-330	8	300	2	200
LKD 61-330	8	370	3	200
LKD 61-330 Mono	8	300	2	200
LKD 61-440	8	535	4	200
LKD 61-550	8	700	5,5	360
LKD 61-550	8	900	7,5	500
LKD 61-555	8	1454	10	500
LKD 2x61-555	8	2908	2x10	800
LKD 81-660	8	1810	15	500
LKD 81-770	2,5	4500	25	1000



LUPAMAT ÇİFT KADEMELİ KOMPRESÖRLER

ÜRÜN KODU	BASINÇ (BAR)	PISTON DEPLASMANI (LT/DK)	MOTOR GÜCÜ (HP)	DEPO HACMİ(LT)
LKD 62-310	15	160	1,5	200
LKD 62-310 Mono	15	160	1,5	200
LKD 62-310 A	15	190	2	200
LKD 62-310A Mono	15	190	2	200
LKD 62-520	15	400	4	200
LKD 62-442	15	496	5,5	360
LKD 62-553 A	15	741	7,5	500
LKD 2x62-553 A	15	1482	2x7,5	800
LKD 82-740	12	2250	25	760



AYDIN TRAFİO ÇİFT KADEMELİ KOMPRESÖRLER

TEKNİK ÖZELLİKLERİ	22-220	22-220M	22-300/5,5	22-530/5,5	22-530/7,5	22-530/10	22-1000/15
ÇALIŞMA BASINCI (BAR)	12	12	12	12	12	12	12
HAVA EMI (LT./DAK.)	200	200	630	630	800	1225	1730
MOTOR GÜCÜ (KW/HP)	1,5/2	1,5/2	4/5,5	4/5,5	5,5/7,5	7,5/10	11/15
VOLTAJ/FAZ (VOLT)	380/3	220/1	380/3	380/3	380/3	380/3	380/3
DEPO HACMİ (LT.)	200	200	300	530	530	530	1000
KOMPRESÖR DEVRİ (RPM)	980	980	950	950	815	1250	1075
KADEME SAYISI	2	2	2	2	2	2	2
SİLİNDİR ADEDİ	2	2	2	2	2	2	2
ÖLÇÜLER (EN X BOY X YÜKS.)	62x150x100	62x150x100	65x170x120	77x192x120	77x192x137	77x192x137	175x210x212
KASALI AĞIRLIK (KG.)	130	130	203	295	336	350	815



22-220 ve 22-220 M

22-300-5,5

22-530,5,5

22-530-7,5

AYDIN TRAFİO VİDALI-SABİT KOMPRESÖRLER

TİP	DEBİ(m ³ /dak) 7 Bar 10 Bar 13 Bar	MOTOR GÜCÜ	DEPO HACMİ	GERİLİM FAZ	SES SEVİYESİ(dB)	HAVA ÇIKIŞI	ÖLÇÜLER (enxboyxyüks.)	AĞIRLIK KG
ATV-DK 7,5	1,10 0,90 0,71	7,5/10	530	380/3	67	3/4"	850x2000x1600	530
ATV-18,5	2.20	18.5		380v/3	72	1"	810 x1170 x1370	340
ATV-22	3,60 3,10 2,75	22/30	22/30	380/3	72	1"	810x1170x1370	345
ATV-30	5,10 4,30 3,85	30/40	30/40	380/3	73	1 1/4"	895x1330x1700	648



ATV 18,5



ATV 22



ATV 30



ATV 160



DEPO ÜSTÜ
VİDALI KOMPRESÖR



MARŞLI BENZİNLİ
KOMPRESÖR

AYDIN TRAFİKO TEK KADEMELİ KOMPRESÖRLER

TEKNİK ÖZELLİKLERİ	11-50	11-50 M	21-100	21-100 M	21-130	21-130 M	21-220	21-220 M
ÇALIŞMA BASINCI (BAR)	8	8	8	8	8	8	8	8
HAVA EMİ (LT./DAK.)	110	110	210	210	275	260	400	260
MOTOR GÜCÜ (KW/HP)	0,75/1	0,75/1	1,1/1,5	1,1/1,5	1,5/2	1,5/2	2,2/3	1,5/2
VOLTAJ/FAZ (VOLT)	380/3	220/1	380/3	220/1	380/3	220/1	380/3	220/1
DEPO HACMI (LT.)	50	50	100	100	130	130	200	200
KOMPRESÖR DEVRİ (RPM)	980	980	980	980	1300	1250	980	1250
KADEME SAYISI	1	1	1	1	1	1	1	1
SİLİNDİR ADEDİ	1	1	2	2	2	2	2	2
ÖLÇÜLER (EN X BOY X YÜKS.)	50x88x83	50x88x83	60x115x100	60x115x100	60x130x90	61x130x90	62x150x100	62x150x100
KAŞALI AĞIRLIK (KG.)	60	63	83	83	94	94	130	120
TEKNİK ÖZELLİKLERİ	21-300/5,5	21-530/5,5	21-530/7,5	21-530/10	21-1000			
ÇALIŞMA BASINCI (BAR)	8	8	8	8	8			
HAVA EMİ (LT./DAK.)	780	780	920	1370	1370			
MOTOR GÜCÜ (KW/HP)	4/5,5	4/5,5	5,5/7,5	7,5/10	7,5/10			
VOLTAJ/FAZ (VOLT)	380/3	380/3	380/3	380/3	380/3			
DEPO HACMI (LT.)	300	530	530	530	1000			
KOMPRESÖR DEVRİ (RPM)	950	950	1120	900	900			
KADEME SAYISI	1	1	1	1	1			
SİLİNDİR ADEDİ	2	2	2	2	2			
ÖLÇÜLER (EN X BOY X YÜKS.)	65x170x120	77x192x134	77x192x134	77x192x150	ŞASE TANK			
KAŞALI AĞIRLIK (KG.)	203	295	295	384	72X130X187 107X120X230	397	303	



21-100 ve 21-100 M

21-220

21-300-5,5

21-530-5,5

ÇAKMAKLI-ELEKTRİKLİ KOMPRESÖRLER



TRAKTÖR KOMPRESÖRLERİ

ÇİFT PİSTON



ŞARTLANDIRICILAR



YEDEK PARÇA

HORTUM VE REKORLARI



MOTOR BAĞLAMA VE ASKI APARATLARI

3 AYAKLI MOTOR ASKISI

ÜNİVERSAL MOTOR ASKISI (ÜÇ AYAKLI) 300 KG KALDIRMA KAPASİTESİNE SAHİPTİR. HER MARKA VE MODEL ARAÇ İÇİN KULLANILABİLİR. 1600 MM KADAR GENİŞLEYEBİLEN MOTOR ASKISI MIN:210 MM MAX:360 MM KADAR OLAN DENGELİYİCİ KOLUYLA MOTORU RAHATÇA ASKIYA ALMAYI KOLAYLAŞTIRIR. AYAKLARI PLASTİK KILIF İLE KAPLI OLDUĞUNDAN DOLAYI KAPORTAYA ZARAR VERMEZ. MOTORU İKİ NOKTADAN KOLAYCA KAVRAMANIZA OLANAK SAĞLAR. ERGONOMİKTİR.



2 AYAKLI MOTOR ASKISI

2 AYAKLI MOTOR ASKISI 300 KG KALDIRMA KAPASİTESİNE SAHİPTİR. HER MARKA VE MODEL ARAÇ İÇİN KULLANILABİLİR. 1600 MM KADAR GENİŞLEYEBİLEN MOTOR ASKISININ AYAKLARINDA KAÜÇUK LASTİKLER OLDUĞUNDAN DOLAYI KAPORTAYA ZARAR VERMEZ. DAYAMA AYAKLARI ÖNE VE ARKAYA DOĞRU AYARLANABİLİR. MOTORU TEK NOKTADAN KOLAYCA KAVRAMANIZA OLANAK SAĞLAR. ERGONOMİKTİR.



VW ÖZEL MOTOR ASKI APARATI

VOLKSWAGEN MARKA ARAÇLARIN TÜM MODELLERİ İÇİN KULLANILABİLİR. MOTOR ASKISININ AYAKLARINDA KAÜÇUK LASTİKLER OLDUĞUNDAN DOLAYI KAPORTAYA ZARAR VERMEZ. MOTORU İKİ NOKTADAN KOLAYCA KAVRAMANIZA OLANAK SAĞLAR. ERGONOMİKTİR.



2 AYAKLI MOTOR ASKI APARATI

2 AYAKLI MOTOR ASKISI 300 KG KALDIRMA KAPASİTESİNE SAHİPTİR. HER MARKA VE MODEL ARAÇ İÇİN KULLANILABİLİR. HAREKETLİ ASKI KÖLU HER NOKTADAN MOTORU ASKIYA ALMANIZA OLANAK SAĞLAR. 1600 MM KADAR GENİŞLEYEBİLEN MOTOR ASKISININ AYAKLARINDA KAÜÇUK LASTİKLER OLDUĞUNDAN DOLAYI KAPORTAYA ZARAR VERMEZ. DAYAMA AYAKLARI ÖNE VE ARKAYA DOĞRU AYARLANABİLİR. MOTORU TEK NOKTADAN KOLAYCA KAVRAMANIZA OLANAK SAĞLAR. ERGONOMİK VE ÇOK FONKSİYONELDIR.



MOTOR BAĞLAMA VE ASKI APARATLARI

CARASKAL

TONAJ:1
BOY (CM): 150
DİŞ EN (CM): 98
YÜKSEKLİK (CM): 160
AĞIRLIK (CM): 120

TONAJ: 2
BOY (CM): 200
DİŞ EN (CM): 130
YÜKSEKLİK (CM): 185
AĞIRLIK (CM): 170



EINHELL ELEKTRİKLİ VİNÇ

KALDIRMA KAPASİTESİ:1000KG
YÜKSEKLİK: 2.5M
AĞIRLIK: 9.4 KG



EINHELL ZİNCİRLİ VİNÇ

KALDIRMA KAPASİTESİ:125 KG KASNAKSIZ
250 KG KASNAKLI
AĞIRLIK: 10,8 KG
GÜÇ: 500W S3 20%



HAVALI KÖRÜKLÜ

3 TON
2 KADEME



SAPSIZ

3 TON
2 KADEME



BŞR-50

20-40 TON
2 KADEME



BŞR-51

15-30-40-70 TON
4 KADEME



BŞR-53

10 TON
ŞİŞE TİPİ



BŞR-54

30 TON
ŞİŞE TİPİ



GARAJ TİPİ HİDROLİK KRİKOLAR



2,5 TON ALÇAK PROFİL KRİKO FORMULA

2 TON KARTON KRİKO

3 TON SEY KRİKO

3TON UGR AYAK PEDALLI KRİKO

AYKUŞ HİDROLİK KRİKOLARI

MODEL	KALDIRMA YÜKSEKLİĞİ	KRİKO YÜKSEKLİĞİ	BOY	GENİŞLİK	AĞIRLIK
2 TON	37 CM	15 CM	110cm	25.5 CM	47 KG
3 TON	38 CM	19 CM	120cm	28.5 CM	58 KG
5 TON	40.5 CM	21 CM	135cm	30.5 CM	80 KG
5 TON UZUN	40 CM	21 CM	160cm	30.5 CM	85 KG
10 TON	40 CM	22 CM	160cm	45.5 CM	128 KG



BAŞAKCI HİDROLİK KRİKOLARI



BSR 01 2 TON ALÇAK PROFİL KRİKO

BSR 03 3 TON HİDROLİK KRİKO

BSR 04 5 TON HİDROLİK KRİKO

BSR 05 10 TON KISA KRİKO

BSR 09 20 TON KRİKO

BSR 10 30 TON KRİKO

BSR 11 8 TON HİDROLİK KRİKO

ŞİŞE TİPİ HİDROLİK KRİKOLAR



HİDROLİK PRES

MODEL: PRESS
TONAJ (TON): 20
BOY (CM): 160
GENİŞLİK (CM): 50
EN (CM): 16
PİSTON BOYU(CM): 20
AĞIRLIK (KG): 110



AMORTİSÖR SÖKMEKRİKOSU

MODEL:A.S.K
YÜKSEKLİK: 115CM
UZUNLUK: 50CM
GENİŞLİK: 35CM
AĞIRLIK: 30KG



ŞANZİMAN VE DİFFERANSİYEL KRİKOLARI

DİKEY ŞANZİMAN KRİKOSU

MODEL: D.Ş.K.
YÜKSEKLİK (CM): 110
UZUNLUK (CM): 57
GENİŞLİK (CM): 57
TAŞIMA KAPASİTESİ (KG): 750
AĞIRLIK (KG): 34



ŞANZİMAN DEFRANSİYEL KRİKOSU

MODEL: Ş.D.K.
TONAJ (TON): 1
BOY (CM): 119
GENİŞLİK (CM): 62.5
İNİK YÜKSEKLİK (CM): 15
KALKIK YÜKSEKLİK: 15
AĞIRLIK (KG): 80



ARAÇ ALTI SEHPA



YATAY ŞANZİMAN KRİKOSU



DİKEY ŞANZİMAN KRİKOSU 1000



DİKEY ŞANZİMAN KRİKOSU 500

KAPORTA SİSTEMLERİ



SPOT 3000



SPOT 6500



SPOT 3000



SPOT 3000

YIKAMA MAKİNALARI

ÖZMEN



3060 SLX SOĞUK YIKAMA MAK.



3060 SLX SICAK-SOĞUK YIKAMA MAK. TURBO

MODEL	POMPA	MOTOR	LT/DK	BAR	AKSESUAR
3060 SLX	ÖZMEN	7.5 HP,5.5KW, 380 V	13	200	10 M HOR
3060 SLX TURBO	ÖZMEN	7.5 HP,5.5KW, 380 V	13	200	10 M HOR

YIKAMA MAKİNALARI - SANAYİ TİPİ SÜPÜRGELEK



HP 200



SC-43



HP 150



9060-8060 2-3 MOTORLU SANAYİ TIP 220 W



WD 62



WD 73



WD753

HALI-KOLTUK YIKAMA



BSR 260 TAM OTOMATİK HALI YIKAMA MAK. 3 FIRÇALI



HALI SIKMA MAKİNASI RL 1400 T 40CM TAMBUR BOYU 2.7MM3.14.20MM İÇ TAMBUR



ISW 4000 CLEANVAC SICAK-SOĞUK BUHARLI HALI KOLTUK YIK.MAK.



SC42 HALI YIKAMA CİLALAMA MAK.ÇİFT TARAFLI START-STOP ŞANZİMANLI GÜÇ AKTARIM SİSTEMLERİ



SURENA SC42 HALI YIK. VE CİLALAMA MAK. ÇİFT TARAFLI START STOP.

WASHPRATIC ÇİLALI/JETONLU

1TL 2TL JETON MANYETİK KART KİLİTLİ ŞARTEL İLE ÇALIŞIR. SAHTE PARAYI TANIR. ZAMAN RÖLESİ SAYESİNDE SERVİS SÜRESİ 1-30 DK ARASI 120 LT LİK TANK KAPASİTESİ VARDIR. (MIN.55 ARAÇ KÖPÜKLENEBİLİR) SERVİS SÜRESİ 1.5 DK.DIR.



KÖPÜK LİKİT DETERJAN



ÖZMEN KÖPÜK TANKI 60LT



ÖZMEN KÖPÜK PÜSKÜRTME

WASHPRATIC JETONLU NİTROJEN

1 TL JETON, MANYETİK KART VE KİLİTLİ ŞALTER İLE ÇALIŞIR, SAHTE PARAYI TANIR. ZAMAN RÖLESİ SAYESİNDE SERVİS SÜRESİ 1-6 DAKİKA ARASINDA AYARLANIR. SIFIRLANMAYA NUMARATÖR İLE KAÇ ADET ARAÇA HİZMET VERİLDİĞİ KOLAYCA TAKİP EDİLİR. HAVAYA GÖRE DAHA HAFİFTİR. %2 YE KADAR YAKIT TASARRUFU SAĞLAR. NEM OLMADIĞI İÇİN SICAKLIK DEĞİŞİMLERİNDEN ETKİLENMEZ, LASTİK, SİBOP VE JANT ÖMRÜNÜ UZATIR. KURU VE HAREKETSİZ OLDUĞU İÇİN LASTİK ISINMALARINI AZALTIR, FREN MESAFESİNİ KISALTIR. DOĞRU BASINÇ DEĞERİNİ DAHA UZUN SÜRE MUHAFAZA EDER. YAKIT VE LASTİK TASARRUFU SAĞLADIĞI İÇİN ÇEVRE DOSTUDUR. ARAÇ BAŞINA BİRİM MALİYET MAKSİMUM 5 KURUŞTUR (5 DAK. SERVİS SÜRESİ İÇİN)



WASHPRATİK JETONLU

1TL 2TL JETON MANYETİK KART KİLİTLİ ŞARTEL İLE ÇALIŞIR.SAHTE PARAYI TANIR. ZAMAN RÖLESİ SAYESİNDE SERVİS SÜRESİ 1-30 DK ARASI SIFIRLANMAYAN NUMARATÖR İLE KAÇ ARAÇA HİZMET VERDİĞİ TAKİP EDİLEBİLİR. 200-250 BAR BASINÇLI SU ÜRETEYEN İTALYAN VE YERLİ POMPA VARDIR. TETİKLİ GÜVENLİK SİSTEMİ MEVCUTTUR.SİSTEM ÇALIŞSA BİLE TETİĞE BASILMADAN MOTOR VE POMPA DEVREYE GİRMEZ. DAKİKADA 15LT SU TÜKETİMİ VARDIR. ELEKTRİK TÜKETİMİ İLE BİRLİKTE ARAÇ BAŞINA MALİYET MAK.25 KRŞ.TUR. 4 DK.SERVİS SÜRESİ VARDIR.



20LT SIVI PÜSKÜRTME POMPASI



60LT SIVI PÜSKÜRTME POMPASI



90LT SIVI VE KÖPÜK PÜSKÜRTME (ÇİFT TABANCALI)



KÖPÜK PÜSKÜRTME POMPASI

WASHPRATİK PARFÜM

50KR- 1TL JETON MANYETİK KART KİLİTLİ ŞARTEL İLE ÇALIŞIR.SAHTE PARAYI TANIR. ZAMAN RÖLESİ SAYESİNDE SERVİS SÜRESİ 1-30 DK ARASI SIFIRLANMAYAN NUMARATÖR İLE KAÇ ARAÇA HİZMET VERDİĞİ TAKİP EDİLEBİLİR. 3 MT.LİK SİRAL HORTUM VE TETİKLİ-TABANÇASI BULUNMAKTADIR. ARAÇ BAŞINA BİRİM MALİYETİ MAK.10K DUR. SERVİS SÜRESİ 30SN.DI R.



WASHPRATİK JETONLU

1TL 2TL JETON MANYETİK KART KİLİTLİ ŞARTEL İLE ÇALIŞIR.SAHTE PARAYI TANIR. ZAMAN RÖLESİ SAYESİNDE SERVİS SÜRESİ 1-30 DK ARASI SIFIRLANMAYAN NUMARATÖR İLE KAÇ ARAÇA HİZMET VERDİĞİ TAKİP EDİLEBİLİR. 4200 WATT EMİŞ GÜCÜNE SAHİP İSLAK/ KURU 3 MOTORLUDUR. 60LT HACİMLİ TOZ KAZANI İÇİNDE ÖZEL FLANŞLI KEÇE TOZ TORBASI BULUNMAKTADIR. 4,5MT KENDİNDEN SARMALI ESNEK HORTUMU FOTOSELLİ LED PANEL TEPE LAMBASI SERVİS SÜRESİ 5DK.DIR.



TAMİRCİ KIZAĞI



KATLANIR TAMİRCİ KIZAĞI

TAMİRCİ KIZAĞI

KÖPÜK VE SIVI PÜSKÜRTME TANKI

ÖZSAN-YIKAMA

KARTERDEN YAĞ EMME POMPALARI



AMATÖR TİP 30+4.5LT



HUNİLİ 80+9LT



TAVALI FANUSSUZ
80+20LT



TAVALI FANUSSUZ
80+40LT



TAVALI FANUSLU
80+7+20LT



TAVALI FANUSLU
80+7+40LT



20LT SIVI PÜSKÜRTME
POMPASI



ELEK.YAĞ EMME
80+9LT



YAĞ BOŞALTMA HAZNESİ

TRANSFER POMPALARI



HUNİSİZ YAĞ EMME
POMP. 80+9LT



FANUSSUZ KARTERDEN
YAĞ EMME POMP.80LT



FANUSSUZ HUNİLİ YAĞ
EMME POM 50LT



BAŞAK ÇEVİRMELİ VARİL
POMPASI

GRES POMPALARI



MEK.GRES POMP
20KG



GRES
POMP.10KG-45.1



GRES POMP.TENEKE
TIP 16KG 45.1



GRES POMP. 50KG-
45.1



GRES POMP.10KG-7.1



GRES POMP.30KG-70.1



GRES
POMP.50KG-70.1



GRES POMP. TENEKE
TIP
16KG-70.1



GRES POMP. 30KG
BÜYÜK TEKER KAPLIN
VE HORTUMLU
3 METRE



MEK.İNCE YAĞ TAKYİE
POMP. 80LT



MEK.İNCE YAĞ
POMP.18LT



MEK.İNCE YAĞ POMP.
25LT



İNCE YAĞ POMP.
30LT 5.1



İNCE YAĞ POMP.
50 LT. 5.1



İNCE YAĞ POMP.
80LT-5.1



HAVALI İNCE YAĞ
TAKYİE POMP. 80LT



HAVALI İNCE YAĞ
POMP.(EMİŞLİ) 80LT



HAVALI İNCE YAĞ
POMPASI

YEDEK PARÇA



YAĞLAMA MAKİNALARI

GRES POMPALARI



TAVALI FANUSLU 80+7+20LT



TAVALI FANUSLU 80+7+20LT



TAVALI FANUSLU 80+7+20LT



TAVALI FANUSLU 80+7+20LT



BİRLİK KASERLER



BYPASS



GRES HORTUMLARI



VARİL KAPAĞI



YAG BASKI TABLASI



YAĞLAMA ÇUBUKLARI



TAŞLAMA MOTORLARI VE TAŞLARI



TAŞ GRUBU



BİLGİ YOK



SULU TAŞ MOTORU



TAŞ MOTORU 20-32



BİLGİ YOK



BİLGİ YOK



BİLGİ YOK

MENGENE - İŞKENCE

ANMA ÖLÇÜSÜ	AÇILMA MİKTARI	AĞIRLIK
100 MM	100 MM	7,5 KG
125 MM	125 MM	11 KG
150 MM	150 MM	16,6 KG



MATKAP MENGENELERİ (ÇELİK AĞIZLI)

ANMA ÖLÇÜSÜ	AÇILMA MİKTARI	AĞIRLIK
100 MM	100 MM	9 KG
125 MM	130 MM	10 KG
150 MM	155 MM	14 KG
175 MM	180 MM	16 KG
200 MM	205 MM	18 KG



CAN MODEL TESVİYECİ MENGENESİ

ANMA ÖLÇÜSÜ	AÇILMA MİKTARI	AĞIRLIK
100 MM	100 MM	9 KG
125 MM	130 MM	10 KG
150 MM	155 MM	14 KG
175 MM	180 MM	16 KG
200 MM	205 MM	18 KG



YALÇIN BORU SIKMA SİSTEMLİ TESVİYECİ MENGENELERİ (ÖRSLÜ-ÇELİK)



3 Y/5 YALÇIN SAC MAKASI
4MM SAC VE LAMA
6MM YUVARLAK
AĞIRLIK:17 KG.
AYARLANABİLİR BİÇAK SİSTEMİ



3 Y/7 YALÇIN SAC MAKASI
3MM SAC VE LAMA
6MM YUVARLAK
AĞIRLIK:21 KG.
AYARLANABİLİR BİÇAK SİSTEMİ

1" SOMUN SÖKMELER



285 B6 1" AĞIR TİP HAVALI
BIJON SIKMA TABANÇALARI



SUNTECH SG-0707S&L
PİMLİ ÇEKİÇ



INGER-SOLLRAND 285 A 6
1" AĞIR TİP HAVALI BIJON
SIKMA TABANÇALARI

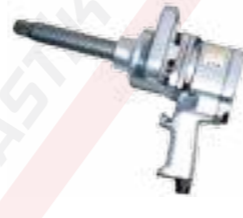

KAWASAKI 421PL 1" AĞIR
TİP HAVALI BIJON SIKMA
TABANÇALARI



KPT-321PL
TEK ÇEKİÇ



KUKEN 380P 1"



KAWASAKI 450 S-SL
1" AĞIR TİP HAVALI BIJON
SIKMA TABANÇALARI



SUNTECH SG-0704S & L1
TEK ÇEKİÇ

3/4" SOMUN SÖKMELER



KPT-25DC KOMPOZİT GÖVDE
2 ÇEKİÇ KOMPOZİT GÖVDE



KPT220P 3/4 HAVALI BIJON
SIKMA TABANÇASI



KPT-1460
DARBE PİMLİ



SG-0740
TEK ÇEKİÇ



SG-0751
TEK ÇEKİÇ



SG-0752
İKİZ ÇEKİÇ



SM-45P COMPOSITE
İKİZ ÇEKİÇ

LOKMALAR



POP PERÇİN TABANÇALARI



SUNTECH SG-0810 5MM



SUNTECH SG-0814 6MM

1/2" SOMUN SÖKMELER



INGERSOL 231 GXP İKİZ ÇEKİÇ



KPT - 231 İKİZ ÇEKİÇ



KAWASAKI 14 SH 1/2"
HAVALI BIJON SIKMA
TABANÇALARI



SUNTECH SM-43-4033 P1
COMPOSITE
TEK ÇEKİÇ



KUKEN 19HP 1/2 "
KUKEN HAVALI BIJON
SIKMA TABANÇALARI



OPC-51212- C/CL
ÇİFT ÇEKİÇ



OPT-P-303 ÇİFT ÇEKİÇ



SUNTECH SET SM-403K
TEK ÇEKİÇ



SUNTECH SG-0717
PİMLİ ÇEKİÇ

CIRCİR MOTORLARI



CP871



KPT-20TR DİŞİ CIRCİR
MAX TORK 4000KG
DEVİR 450 DK/DK



KPT-1175
MAX TORK 1700KG
DEVİR 160 DK/DK



OPT-360 CIRCİR SET



SG-0719-14
MAX TORK 3000 KG
DEVİR 240 DK/DK



SUNTECH SM-30
MAX.TORK 7KG
DEVİR 150 DK/DK



SUNTECH SG-0735
MAX.TORK 12KG
DEVİR 150 DK/DK

KALIPÇI TAŞLAMALAR



KPT-22DG BS 25000DEVİR-DK KPT-24DG 23000 DK DEVİR KPT-26DGBS 15000 DK-DK KPT-28DGS DEVİR 38000 KPT-3200 DEVİR 23000 DK KPT-NG45A-CS 6MM 20000 DVR KPT-PG3 3MM 55000 DVR

SUNTECH SM-501C 22000 DEVİR-DK SUNTECH SM-512 22000 DEVİR-DK SUNTECH SM-522 90 DRC 22000 DEVİR SUNTECH SM-532 25000 DEVİR-DK SUNTECH SM-545 4500 DEVİR SUNTECH SM-552 25000 DEVİR SUNTECH SM-661 HAVALI KAUÇUK TAŞLAMA ŞİPŞAKLI 2600 DVR SUNTECH SM-5001 DEVİR 12000 DK

MATKAPLAR



KPT-63D 10 MM SAĞ 2500 DVR KPT-66ADR 13MM SAĞ SOL 450 DVR KPT-71 13MM SAĞ SOL 500 DVR KPT-1651 10 MM SAĞ 2400 DVR KPT-6810MM SAĞ-SOL 2200 DVR

YÜZEY TEMİZLEME SUNTECH SM-6K-3011B 10MM SAĞ 2500 DVR SUNTECH SM-704 13MM SAĞ-SOL 800 DVR SUNTECH SM-705 10MM SAĞ-SOL 1800 DVR SUNTECH SM-706 10 MM TEK YÖN 2600 DVR SUNTECH SM-709 10MM SAĞ-SOL 1900 DVR

SUNTECH SM-709R 10 MM SAĞ-SOL 1500 DVR SUNTECH SM-710 10 MM SAĞ 2600 DVR SUNTECH SM-746 10MM SAĞ 4500 DVR SUNTECH SM-502 10 MM SAĞ 22000 DVR SUNTECH SM-703 13 MM SAĞ 500 DVR

HAVA SAATLERİ



RAPID MEKANİK HAVA SAATI SLIM SPIRO ELEKTRONİK HAVA SAATI GÖSTERGELİ HS 1029 GÖSTERGELİ HS 1011

SCHRADER PCLMK 3 SCHRADER KOMPLE SPRAL TAŞLAMA MOTORLARI HAVA SAATI ÇUBUK

GÖSTERGELİ HAVA SAATI PCL ACCURA DİJİTAL HAVA SAATI PCL AIR FORCE ANALOG HAVA SAATI PCL HAVA MAKARASI

İNGİLTERE MENŞEİLİ 15M HAVA HORTUMU UZUNLUĞU YAYLI GERİ SARMA SİSTEMİ DUVARA MONTAJ ÖZELLİĞİ

HAVA BASMA JAKLARI-BALANSERLER



HAVA BASMA JAKLARI OPT 30 1.5 3KG AĞIRLIK 1.5MT SB-1200 HALAT BOYU 90CM.(1,5-2,00-3,00-5,00 KG KAPASİTE)

TARIM GRUBU

BL110	BL120	BL250	BL310	BL320
4.00-8 4PR	6.00-16 6 PR	155/80-13 TT	7.50-16	9.00-16
4.00-8 6PR	6.00-16 8PR			
4.00-16 4PR TL	6.50-16			
6.50/80-12 6PR	7.50-16			
6.50/80-13 6PR				
5.00-12 4PR				
5.00-15/6				
6.50/80-15-6				
7.50-16/8				



BİSİKLET VE ELEKTİRİKLİ BİSİKLET DIŞ LASTİKLERİ

B52	B54	B58	B62	B63	B70	B71	B72
27X1.1/4	24X1.3/8	26X1.1/2	16X1.75	26X2.00	16X2.125	20X2.125	20X2.125
	26X1.3/8	28X1.1/2	18X1.75		20X2.125		
	28X1.3/8		20X1.75				
			22X1.75				
			24X1.75				
			26X1.75				
			28X1.75				
			26X2.00				
			26X2.125				

B73	B74	B75	B80	B81	B88	B89	B90
20X2.125	16X2.125	12 1/2X1/4	26X1.95	26X1.95	26X1.95	26X2.10	26X1.95
	20X2.125	16X2.125					26X2.10
	24X1.95	26X1.95					
	26X1.95						



EBAT	SUPAP
145/155-12	TR 13
165-13	TR 13
185-14	TR 13
215-R 15	TR 13
6.50-16	TR 13
6.00-16	TR 15
6.00-16	TR218A
6.50-16 BASAK	TR15
6.50-16 KINGS	TR15
6.50-16	TR 75A
6.00-19	TR 15
7.50-16	TR 15
7.00-16	TR177A
7.50-16 BASAK	TR75A
7.50-16 KINGS	TR75A
7.50-16	TR 150
9.00-16 BAŞAK	TR177A
9.00-16 KINGS	TR 177 A
7.50-18	TR 15/75 A
7.50-20	TR 177 A
8.25-20	TR 15/75 A
9.00-20	TR 78 A
9.00-20	VC-04-5
10.00-20	TR 78 A
10.00-20	V3-04-5
11.00-20	TR 78 A
11.00-20	V3-04-5
12.00-20	TR 78 A
12.00-20	V3-04-5
14.00-20	TR 78 A
12.00-24	TR 78 A/218 A
12.00-24	V3-04-5
13.00-24	TR 179 A/218 A
14.00-24	TR 179 A/218 A
10.5/80-18	TR 15/218 A
12.5/80-18	TR 15/218 A
10.5/80-20	TR 15/218 A
12.5/80-20	TR 15/218 A
14.5/80-20	TR 15/218 A
16.0/70-20	TR 15/218 A
16.00-24/25	TRJ 1175 c
18.00-24/25	TRJ 1175 c
15.5-.25	TRJ 1175 c
17.5-.25	TRJ 1175 c
20.5-.25	TRJ 1175 c
23.5-.25	TRJ 1175 c
26.5-.25	TRJ 1175 c
29.5.25	TRJ 1175 c

EBAT	SUPAP
4.00-4	TR 13
3.50/4.00-6	TR 13
13X5.00-6	TR 13
4.00-7	TR 13
18X7.00-8	JS 87
5.00/5.70-8	JS 2
6.00/6.90-9	JS 2
6.50-10	JS 2
7.50-10	JS 2
4.00-12	TR 13
5.00-12	TR 13
6.00-12	TR 13
7.00-12	TR 75 A
10.0/80-12	TR 15
9.00-13	TR 15
7.5L-15	TR 15
9.5L-15	TR 15
2.50/3.00-15	TR 15
5.00-15	TR 15
6.50-15	TR 15
7.50-15	TR 15/75 A
8.15-15	TR 75 A
28X90-15	TR 75 A
8.25-15	TR 75 A
10.00-15	TR 78 A
11L-15	TR 15
12.5L-15	TR 15
10.0/75-15	TR 15
10.0/75-15.3	TR 15
11.5/80-15	TR 15
12.5/80-15	TR 15
4.00/60-15.5	TR 15
11L-15/16	TR 15
10.00-16	TR 15/218 A
11.00-16	TR 15 /218 A
10.5/65-16	TR 15
11.5/70-16	TR 15
13.0/75-16	TR 15
13.5/16-1	TR 15 /218 A
13.0/65-16	TR 15
14.0/65-16	TR 15
14L/16.1	TR 15/218 A
11.12.-15	TR 15
13.5/75-17	TR 15
15.0/55-17	TR 15
19.0/45-17	TR 15
4.00-19	TR 15
8.00-19	TR 15

BİNEK GRUP İÇ LASTİKLERİ

EBAT	SUPAP
8.3/8-24	TR 218 A
9.5/9-24 9.3/9-24	TR 218 A
11.2/10-24	TR 218 A
12.4/11-24	TR 218 A
13.6/12-24	TR 218 A
14.9/13-24	TR 218 A
16.9/14-24	TR 218 A
15.5/80-24	TR 218 A
16.5/80-24	TR 218 A
14.9/13-26	TR 218 A
16.9/14-26	TR 218 A
18.4/15-26	TR 218 A
23.1.-26	TR 218 A
11.2-10-28	TR 218 A
12.4/11-28	TR 218 A
13.6/12-28	TR 218 A
14.9/13-28	TR 218 A
16.9/14-28	TR 218 A
18.4/15-28	TR 218 A
16.5/80-28	TR 218 A
14.9/13-30	TR 218 A
16.9/14-30	TR 218 A
18.4/15-30	TR 218 A
23.1.1-30	TR 218 A
8.3/8-32	TR 218 A
9.5/9-32	TR 218 A
12.4/11-32	TR 218 A
16.9/14-34	TR 218 A
18.4/15-34	TR 218 A
23.1-34	TR 218 A
8.3/8-36	TR 218 A
9.5/9-36	TR 218 A
11.2/10-36	TR 218 A
12.4-11-36	TR 218 A
13.6/12-36	TR 218 A
11.2/10-38	TR 218 A
12.4/11-38	TR 218 A
13.6/12-38	TR 218 A
14.9/13-38	TR 218 A
16.9/14-38	TR 218 A
18.4/15-38	TR 218 A
15.5-.38	TR 218 A



MOTORSİKLET VE MOPED DIŞ LASTİKLERİ

B10	B11	B12	B14	B15
2.25-17	2.75-18F TL	2.25-17F	2.50-16	3.00-17
2.50-17	2.75-18F	2.50-17F	2.25-17	2.25-19
2.50-17 TL		2.75-17F		
2.75-17		2.50-17F		
2.75-17 TL		2.50-18F		
2.28-18				
3.00-18				
3.00-18 TL				
3.25-18				
3.50-18				
2.00-19				
2.50-19				
3.25-19				
3.50-19				



SCOOTER DIŞ LASTİKLERİ

B30	B32	B35	BL45	BL50	BL55	BL089
3.50-7	3.50-10 4PR	3.50-10 4PR	110/90-12 4PR TL	120/70-12 4PR TL	120/90-10 4PR TL	90/90-10 4PR TL
3.50-7 TL	3.50-10 8PR	3.50-10 8PR	110/90-12 8PR TL	120/70-12 8PR TL	120/90-10 6PR TL	100/90-10 4PR TL
3.50-8 2PR	3.50-10 8PR TL	3.50-10 4PR TL	130/60-13 4PR TL	130/70-12 4PR TL	130/90-10 4PR TL	90/90-12 4PR TL
3.50-8 4PR	3.50-10 4PR	3.50-10 8PR TL	130/60-13 8 PR TL	130/70-12 8PR TL	3.50-10 8PR TL	100/90-10 6PR TL
3.50-8 6PR				130/60-13 4PR TL		
3.50-8 8PR				130/60-13 8PR TL		
3.50-8 10PR						
4.00-8 10PR						
4.00-8 4PR TL						
4.00-8 2PR TL						



IMPLEMENT GRUP

B30	B31	B33	B35	B36	B37	B40	BL401
3.50-7 (2PR)	4.00-4.80-8 2PR	3.00-12 4PR	4.50-10 4PR	4.00-8 2PR	5.00-10 8PR	5.00-12 4PR	5.00-12 4 PR
3.50-7 (2PR) TL			4.50-10 8PR	4.00-8 4PR	5.00-10 4PR		
3.50-8 (2PR)				4.00-8 6PR	5.00-10 4PR		
3.50-8 (4PR)				4.00-8 8PR			
3.50-8 (6PR)				5.00-10 4PR			
3.50-8 (8PR)							
3.50-8 (10PR)							
4.00-8 (2PR)							
4.00-8 (4PR)							
4.00-8 (6PR)							
4.00-8 (8PR)							
4.00-8 (10PR)							
4.00-8 (4PR) TL							
4.00-8 (2PR) TL							



KOLONLAR



16"KOLON	20"KOLON	24"KOLON
9"-10"-12"KOLON	15.5/17.5-25"	20.5/23.5-25"



BAŞAKÇI LASTİK®

YARDIMCI MALZEMELERİ ve GARAJ EKİPMANLARI TİC.



BAŞAKÇI
TEAM
TYRE EQUIPMENT'S

BAŞAKÇI TEAM YAMALAR

MODEL RADIAL	SIZE mm	PLY RATING					
RAD-08	45 x 68	1	●				
RAD-10	55 x 75	1	●				
RAD-12	70 x 115	1	●				
RAD-14	85 x 130	1	●				
RAD-15	75 x 90	1	●	●	●		
RAD-16	67 x 104	1	●				
RAD-18	75 x 100	2		●	●	●	
RAD-20	80 x 125	2		●	●	●	
RAD-22	75 x 175	2		●	●	●	
RAD-24	75 x 225	2			●	●	
RAD-25	115 x 125	3			●	●	
RAD-26	75 x 260	3			●	●	
RAD-28	75 x 330	3			●	●	
RAD-33	100 x 125	3			●	●	
RAD-35	130 x 180	4			●	●	
RAD-40	100 x 200	3		●	●	●	
RAD-42	130 x 265	4		●	●	●	
RAD-44	130 x 335	4			●	●	
RAD-45	180 x 230	4			●	●	
RAD-46	180 x 440	4			●	●	
RAD-50	180 x 580	5			●	●	
RAD-52	240 x 580	5			●	●	
RAD-55	260 x 330	5				●	●
RAD-56	275 x 720	7				●	●
RAD-60	270 x 860	7				●	●
RAD-62	1000x325	7				●	●
RAD-65	330 x 420	6				●	●
RAD-68	350 x 760	7				●	●
RAD-75	450 x 530	8				●	●
RAD-80	150 x 190	2				●	●
RAD-82	185 x 240	3				●	●
RAD-84	215 x 295	3				●	●
RAD-85	530 x 730	8				●	●
RAD-86	245 x 340	3				●	●
RAD-88	280 x 450	2				●	●
RAD-90	310 x 550	2				●	●



MARUNİ YAMALARI



MARUNİ GNR
LASTİK YAMASI
(RADYAL-LASTİKLER)



MARUNİ GUT
DIŞ LASTİK TAMİR
YAMASI
ÇİVİ DELİKLERİ İÇİN



MARUNİ
İÇ LASTİK YAMASI
(OVAL)



MARUNİ
İÇ LASTİK YAMASI
(YUVARLAK)



YAMA KUŞINGAMI



MC MANTAR
YAMALAR



LASTİK FİTİLİ



MARUNİ SEALINER
SOLÜSYON 1000 CC
LASTİK YAMASI
ÖMRÜNÜ UZATAN
SOLÜSYON



MARUNİ
SÜPER VALKARN
SOLÜSYON 100CC
200CC 1000CC RADYAL
LASTİK YAMALARI İÇİN



MARUNİ BEAD SEALINER
SOLÜSYON 1000 CC (LAS-
TİK VE JANT ARASI
SIZDIRMAZLIK İÇİN)



VALKARN
İÇ YAMA
SOLÜSYONLARI



MARUNİ
PLUG PATCH
SOLÜSYON
PW3505



MARUNİ
SET



MARUNİ THERMO
LIQOID SOLÜSYON
1000 CC (İÇ LASTİK
SICAK YAMALAR İÇİN)

BEZLİ LASTİK YAMALARI

MONTAJ KREMLERİ VE KAYDIRICILAR

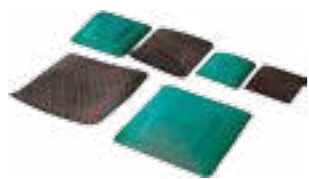

GETLİ TİP TOP



KAUCUKLU TİP TOP



SUBAPLAR



2901 01019
SUBAP



412 TUBLES
SUBAP



414 TUBLES
SUBAP



618 İŞ MAKİNASI
SUBAP



2901 01018
SUBAP



BMW UZUN
SOMUN İNCE TİP
SUBAP



BMW UZUN
SOMUN KALIN TİP
SUBAP



İŞ MAKİNASI
SUBAP JUMBO TİP
KISA



İŞ MAKİNASI
SUBAP JUMBO TİP
UZUN



İŞ MAKİNASI
TUBLES SUBAP
9 CM



İŞ MAKİNASI
TUBLES SUBAP
12 CM



İŞ MAKİNASI
TUBLES SUBAP
15 CM



İŞ MAKİNASI
TUBLES SUBAP
248 U



MOTOSİKLET
SUBAP



PILOT TUBLES
SUBAP



TR 414 METAL
TUBLES SUBAP



TR 148 TUBLES
SUBAP KROM
KILIFLI PLASTİK



TR 413 TUBLES
SUBAP KROM
KILIFLI PLASTİK



TR 414 EĞİMLİ
METAL TUBLES
SUBAP



TR 414 TUBLES
SUBAP KROM
KILIFLI PLASTİK



TR 414
SUBAP



TR 414
SUBAP ALG



TR 414
SUBAP E



TR 414
SUBAP S



TR 415 TUBLES
SUBAP



TR 418 TUBLES
SUBAP



TR 5720
DORSE



TRAKTÖR TUBLES
METAL SIBOP

RASPA TAŞLARI



RASPA BIÇAĞI

595 88 72	Sivri Uçlu Konik Raspa Taşı K18	Ø 25x50 mm max 4500 rpm
595 07 39	Sivri Uçlu Konik Raspa Taşı K18	Ø 25x102 mm max 4500 rpm
595 07 46	Yuvarlak Uçlu Konik Raspa Taşı K18	Ø 20x38 mm max 4500 rpm
595 89 20	Topuz Şaftlı Raspa Taşı K18	Ø 20 mm max 4500 rpm
595 50 57	Kalem Raspa Taşı K36	Ø 4-6x65 mm max 4500 rpm
595 89 06	Kalem Raspa Taşı K18	Ø 5-8x105 mm max 4500 rpm
595 88 96	Kalem Raspa Taşı K36	Ø 5-8x105 mm max 4500 rpm
595 89 68	Kalem Raspa Taşı K18	Ø 8x170 mm max 4500 rpm
595 89 51	Kalem Raspa Taşı K36	Ø 8x170 mm max 4500 rpm
595 87 86	Dairesel Şaftlı Raspa Taşı K18	Ø 50x3 mm max 4500 rpm
595 88 10	Dairesel Raspa Taşı K18	Ø 50x5 mm max 4500 rpm
595 88 58	Dairesel Raspa Taşı K18	Ø 50x10 mm max 4500 rpm
595 43 88	Dairesel Raspa Taşı K18	Ø 50x13 mm max 4500 rpm
595 43 95	Dairesel Raspa Taşı K36	Ø 50x13 mm max 4500 rpm
595 88 27	Dairesel Raspa Taşı K18	Ø 50x19 mm max 4500 rpm
595 88 34	Dairesel Raspa Taşı K18	Ø 76x16 mm max 4500 rpm
595 88 41	Dairesel Raspa Taşı K18	Ø 102x19 mm max 4500 rpm
595 90 00	Küresel Raspa Taşı K36	Ø 30 mm max 4500 rpm
595 88 65	Küresel Raspa Taşı K18	Ø 50 mm max 4500 rpm
595 89 75	Küresel Raspa Taşı K36	Ø 50 mm max 4500 rpm
595 42 23	Küresel Raspa Taşı K18	Ø 76 mm max 4500 rpm
595 42 09	Küresel Raspa Taşı K36	Ø 76 mm max 4500 rpm
595 42 47	Küresel Raspa Taşı K18	Ø 102 mm max 4500 rpm
595 42 30	Küresel Raspa Taşı K36	Ø 102 mm max 4500 rpm
595 42 16	Küresel Raspa Taşı K36	Ø 65 mm max 4500 rpm
595 60 56	Küresel Gümüş Serisi Raspa Taşı K16	Ø 50 mm max 4500 rpm
595 60 87	Küresel Gümüş Serisi Raspa Taşı K16	Ø 76 mm max 4500 rpm
595 61 11	Küresel Gümüş Serisi Raspa Taşı K16	Ø 102 mm max 4500 rpm
595 60 01	Dairesel Gümüş Serisi Raspa Taşı K16	Ø 50x3 mm max 4500 rpm
595 60 18	Dairesel Gümüş Serisi Raspa Taşı K16	Ø 50x5 mm max 4500 rpm
595 60 49	Dairesel Gümüş Serisi Raspa Taşı K16	Ø 50x10 mm max 4500 rpm
595 46 56	Küresel Gümüş Serisi Raspa Taşı K36	Ø 76 mm max 4500 rpm
595 47 35	Küresel Gümüş Serisi Raspa Taşı K60	Ø 32 mm max 4500 rpm
595 43 57	Tubeless Astar Katı Raspa Taşı K36	Ø 65 mm max 4500 rpm
595 43 64	5954357 Polyplug Dengeleyici	Ø 65 mm max 4500 rpm
595 43 71	Topuz Gümüş Serisi Raspa Taşı K36	Ø 19 mm max 4500 rpm
595 47 04	Yuvarlak Uçlu Konik Gümüş Raspa Taşı K18	Ø 22 mm max 4500 rpm
595 47 11	Mini Gümüş Serisi Raspa Seti K60	4 Parça
595 00 83	Topuz Kireçtaşı Şaftlı Raspa Taşı	Ø 38 mm max 4500 rpm
595 43 26	Üçlü Mini Ay Bıçak Seti	Ø 30 mm max 4500 rpm
595 42 92	Ay Bıçak	Ø 50 mm max 4500 rpm
595 44 81	Ay Bıçak Biley Aparatı	
595 25 48	Raspa Diski K23	Ø 125x2 mm max 4500 rpm
595 25 55	Raspa Diski K18	Ø 175x2 mm max 4500 rpm

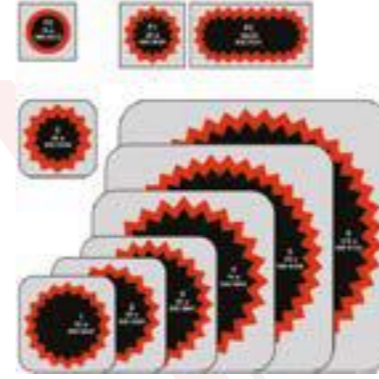

İÇ LASTİK YAMALARI

5007039	NO. 0	Ø 30 mm
5007046	NO. 1	Ø 35 mm
5007053	NO. 2	Ø 45 mm
5007060	NO. 3	Ø 54 mm
5007084	NO. 4	Ø 75 mm
5007101	NO. 5	Ø 94 mm
5007125	NO. 6	Ø 116 mm
5007204	NO. 7	74x37 mm
5007266	NO. 7b	150x75 mm

MINİKOMBI DIŞ LASTİK YAMALARI

5111963	Minikombi A 3	3 mm Kılavuzlu
5113216	Minikombi A 4,5	4,5 mm Kılavuzlu
5113058	Minikombi A 6	6 mm Kılavuzlu
5111963	Minikombi B 8	8 mm Kılavuzlu
5113144	Minikombi B 10	10 mm Kılavuzlu



100 SERİSİ RADIAL DIŞ LASTİK YAMALARI





5121104	RAD 110	75x55 mm 1 kat
5121120	RAD 112	115x70 mm 1 kat
5121140	RAD 114	130x85 mm 1 kat
5121159	RAD 115	90x75 mm 1 Kat
5121160	RAD 116	104x67 mm 1 Kat
5121207	RAD 120	125x80 mm 2 Kat
5121221	RAD 122	175x75 mm 2 Kat
5121245	RAD 124	220x75 mm 2 Kat
5121252	RAD 125	125x115 mm 3 Kat
5121360	RAD 135	203x148 mm 4 Kat
5121403	RAD 140	195x100 mm 3 Kat
5121427	RAD 142	260x130 mm 4 Kat
5121441	RAD 144	335x130 mm 4 Kat



İŞ MAKİNASI DIŞ LASTİK DIAGONAL YAMALAR

5122000	PN 050	240 mm
5122017	PN 050+	240 mm
5122024	PN 052	360 mm
5122031	PN 052+	360 mm
5122048	PN 054	480 mm
5122055	PN 054+	480 mm
5122062	PN 056	660 mm







ÇELİK TEL KESME TAŞLARI

	Sivri Kenar Mantar Kesme Taşı	Ø 32x6 mm 6 mm Şaft max 25000 rpm
	Sivri Uçlu Konik Taş	Ø 14x45 mm 6 mm Şaft max 25000 rpm
	Kalem Taş	Ø 8x25 mm 6 mm Şaft max 25000 rpm
	Uzun Konik Taş	Ø 20x65 mm 6 mm Şaft max 25000 rpm

TEL FIRÇALAR

	Silindirik Plastiğe Gömülü Tel Fırça	Ø 50x7 mm max 2800 rpm
	Silindirik Plastiğe Gömülü Tel Fırça	Ø 76x8 mm max 2800 rpm
	Eğimli Kenarlı Plastiğe Gömülü Tel Fırça	Ø 76x20 mm max 2800 rpm
	Silindirik Dairesel Tel Fırça	Ø 100x25 mm max 2800 rpm
	Sarmal Delik Temizleme Fırçası	Ø 8x25 mm max 2800 rpm
	Dairesel Tel Fırça Şaftlı	Ø 8x55 mm max 2800 rpm

ELMAS KESİCİ & DELİCİ UÇLAR

	Sivri Uçlu Kesici 25 mm	Ø 3x50 mm max 25000 rpm
	Sivri Uçlu Kesici 25 mm	Ø 6x65 mm max 25000 rpm
	Kesik Uçlu Kesici 25 mm	Ø 6x65 mm max 25000 rpm
	Sivri Uçlu Delici 30 mm	Ø 4,5x90 mm max 2500 rpm
	Sivri Uçlu Delici 50 mm	Ø 6x90 mm max 2500 rpm
	Sivri Uçlu Delici 50 mm	Ø 8x100 mm max 2500 rpm
	Sivri Uçlu Delici 60 mm	Ø 10x110 mm max 2500 rpm

ÖZEL SOLÜSYONLAR & KAUÇUKLAR

5059245	İç Lastik Solüsyonu	500 gr
5059692	Sprey Temizleme Solüsyonu	500 ml
5150341	Özel Mavi Solüsyon	TRI 350 gr
5150387	Özel Mavi Solüsyon	TRI 1 kg

ANAHTARLAR VE DİĞER EL ALETLERİ

					
2010	2098	2820	2824	2830	2845
					
2850	2851	2860 S	2861 S	2870 S	2871 S
					
3001 Y	3002 Y	3003 Y	3298	3800	3800 A
					
8160 6434	8272	8352-1 Y	8352-3 Y	8353-1 Y	8353-1 Y
					
8530 R	8605	6701890	A 1500 ES 2020	A 1500 ES 8000	D MG 4434-177
					
D MG 4443-1998	D MG 4555-177E	E 175 SEGMAN	G 105 UU	G 105	I 12 12 TKM CNTS 6447
					
VDE150	PENSE GRUBU 04	BALTA	SDNT 082 KATLANABİLİR TORKS UÇLU ALLEN SETİ	VS102 OTOMATİK KABLO SİYİRİCİ	TU90005E TGT8006

BENZİNLİ EL ALETLERİ



BG PC 4040
BENZİNLİ
1.5KW(2.0HP)



BG PC 5045
BENZİNLİ AĞAÇ KESME
MOTORU 2.KW(3,0HP)

ELEKTRİKLİ EL ALETLERİ



BG EC 2240
ELEKTRİKLİ AĞAÇ
KESME MOTORU
230V 2200W



RT AG 115
AVUÇ TAŞLAMA
230V 600W



RT AG 125 1
DAİRE TAŞLAMA
230V 1.010W



RT AG 230
DAİRE TAŞLAMA
230V 2300W



RT CD 108 LI
AKÜLÜ VIDALAMA



RT CD 108 LI
TAŞIMA ÇANTASI



RT CD 14 4 LI
AKÜLÜ VIDALAMA



RT CS 190 DAİRE
TESTERE
230V 1500W



RT ID 110
DARBELİ MATKAP
130V 1100W



RT JS 85
DEKUPAJ
TESTERE
230V 750W



RT RH 20
KIRICI DELİCİ
230V 600W



RT RH 32
KIRICI DELİCİ
230V 1250W



RT SD 3,6 1 LI
ŞARJLI VIDALAMA



RT SD 3,6 1 LI KIT
ŞARJLI VIDALAMA



BG EC 1840 TC
BENZİNLİ AĞAÇ
KESME MOTORU
230V 1800W



RT HA 2000 E
SICAK HAVA(FÖN)
TABANCASI



RT ID 65
DARBELİ MATKAP
230V 650W



TESTERE BIÇAĞI

TAKIM-TEZGAH DOLAPLARI-TAŞIMA ÇANTALARI



1514 EKO
TAKIM DOLABI



1515 EKO
TAKIM DOLABI



TAKIM DOLABI



1262
TAKIM TEZGAH



1263
TAKIM TEZGAH

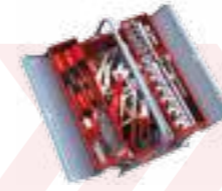

1264
TAKIM TEZGAH



1265
TAKIM TEZGAH



1400
TAKIM DOLABI



1510
TAKIM DOLABI



TAKIM ASKISI



24" TAŞIMA
ÇANTASI



22" TAŞIMA
ÇANTASI



16" TAŞIMA
ÇANTASI



AKORDEON
TAŞIMA ÇANTASI

TORK ANAHTARLARI



3552



LS 3552 K



LS 3552



TESTERE BIÇAĞI

LOKMA ANAHTARLAR

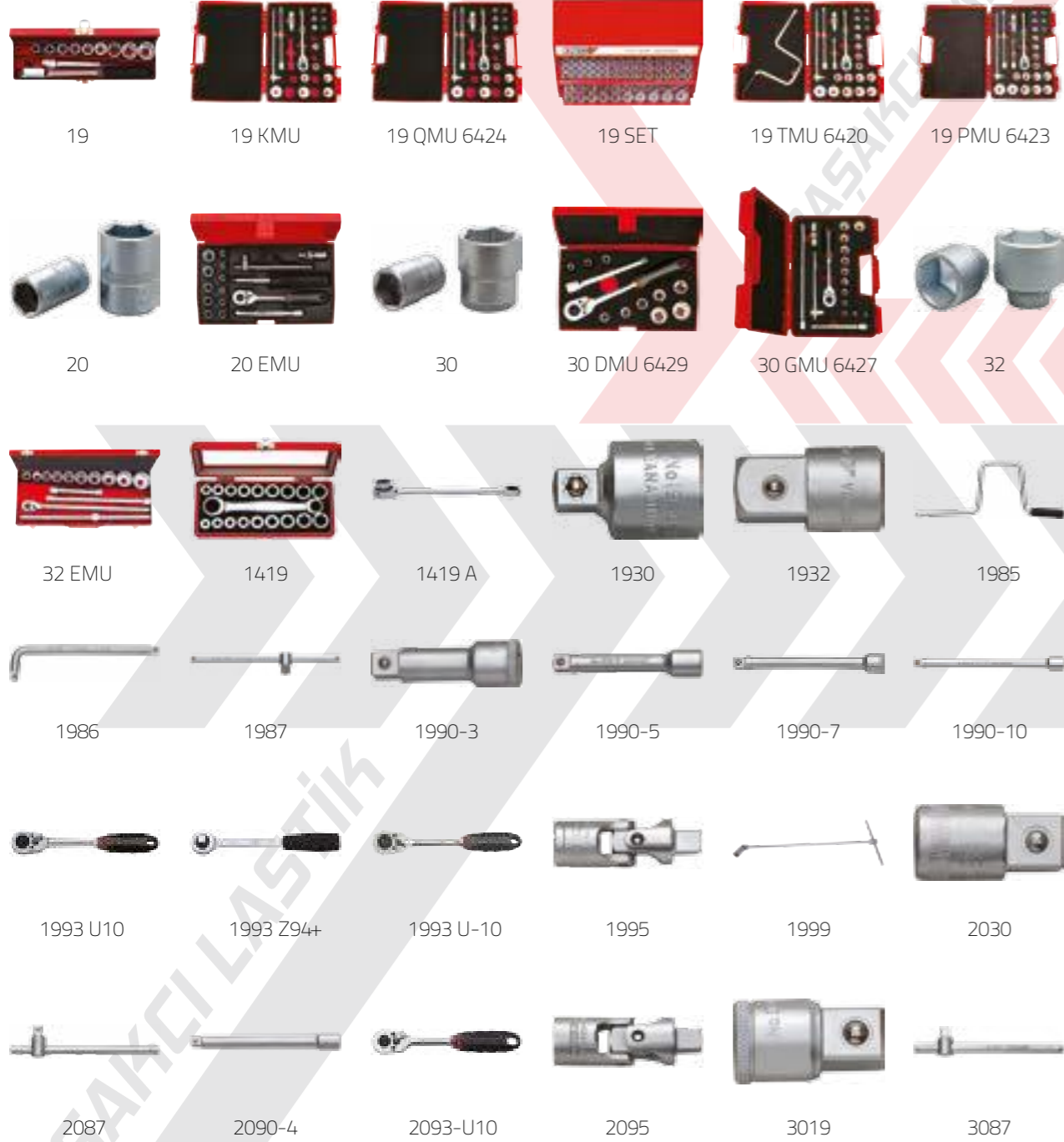

LOKMA ANAHTARLAR



ANAHTARLAR VE DİĞER EL ALETLERİ



025 TEK



ÜRÜN ADI: 1 AKÜLÜK ŞARJ CİHAZI
GİRİŞ VOLTAJI: 220 VOLT AC 50 HZ
GİRİŞ AKIMI: 1.3 AMPER MAX.
ÇIKIŞ VOLTAJI: 9-16 VOLT DC KADEMELİ
ÇIKIŞ AKIMI: 0-25 AMPER KADEMELİ
GÖSTERGELER: ANALOG AMPERMETRE
GİRİŞ KABLOSU: 3X1.5 MM TRR
ÇIKIŞ KABLOSU: 6 MM NYY 1.5 MT KIRMIZI MAŞALI POZİTİF (+)
ÇIKIŞ KABLOSU: 6 MM NYY 1.5 MT SİYAH MAŞALI NEGATİF (-)
BAĞLANTI ŞEKLİ: DÜZ BAĞLANTI
KORUMA / SINIFI: AŞIRI AKIM VE GERİLİM SINIFI 2
ŞARJ KARAKTERİSTİĞİ: I-U AKIM - GERİLİM SOĞUTMA-HAVA SOĞUTMALI
GÜÇ: 250 WATT
EBATLARI: 15 X 15 X 22
AĞIRLIĞI: 8 KG
KULLANIM YERİ: KURŞUN ASİTLİ 45-200AM- PERLİK AKÜ MANUEL ŞARJ EDİLMESİ
GARANTİ SÜRESİ: 2 YIL

153 12



ÜRÜN ADI: 12 AKÜLÜK ŞARJ CİHAZI
GİRİŞ VOLTAJI: 220 VOLT AC 50 HZ
GİRİŞ AKIMI: 20 AMPER MAX.
ÇIKIŞ VOLTAJI: 9-180 VOLT DC KADEMELİ
ÇIKIŞ AKIMI: 0-30 AMPER KADEMELİ
GÖSTERGELER: DİJİTAL AMPERMETRE VE VOLTMETRE
GİRİŞ KABLOSU: 3X1.5 MM TRR
ÇIKIŞ KABLOSU: 16 MM NYY 1.5 MT KIRMIZI MAŞALI POZİTİF (+)
ÇIKIŞ KABLOSU: 16 MM NYY 1.5 MT SİYAH MAŞALI NEGATİF (-)
BAĞLANTI ŞEKLİ: SERİ BAĞLANTI
KORUMA / SINIFI: AŞIRI AKIM VE GERİLİM SINIFI 2
ŞARJ KARAKTERİSTİĞİ: I-U AKIM - GERİLİM SOĞUTMA-HAVA SOĞUTMALI
GÜÇ: 4500WATT
EBATLARI: 44.5 X 66 X 37
AĞIRLIĞI: 70 KG
KULLANIM YERİ: KURŞUN ASİTLİ 45-200AM- PERLİK AKÜ MANUEL ŞARJ EDİLMESİ
GARANTİ SÜRESİ: 3 YIL

S 1218 M



ÜRÜN ADI: 1 AKÜLÜK ŞARJ CİHAZI
GİRİŞ VOLTAJI: 220 VOLT AC 50 HZ
GİRİŞ AKIMI: 1.3 AMPER MAX.
ÇIKIŞ VOLTAJI: 14 VOLT DC KADEMELİ
ÇIKIŞ AKIMI: 0-18 AMPER KADEMELİ
GÖSTERGELER: ANALOG AMPERMETRE
GİRİŞ KABLOSU: 3X1.5 MM TRR
ÇIKIŞ KABLOSU: 6 MM NYY 1.5 MT KIRMIZI MAŞALI POZİTİF (+)
ÇIKIŞ KABLOSU: 6 MM NYY 1.5 MT SİYAH MAŞALI NEGATİF (-)
BAĞLANTI ŞEKLİ: DÜZ BAĞLANTI
KORUMA / SINIFI: AŞIRI AKIM VE GERİLİM SINIFI 2
ŞARJ KARAKTERİSTİĞİ: I-U AKIM - GERİLİM SOĞUTMA-HAVA SOĞUTMALI
GÜÇ: 250WATT
EBATLARI: 24 X 14 X 19
AĞIRLIĞI: 3 KG
KULLANIM YERİ: KURŞUN ASİTLİ 45-200AM- PERLİK AKÜ MANUEL ŞARJ EDİLMESİ
GARANTİ SÜRESİ: 2 YIL

MANUEL AKÜ ŞARJ CİHAZLARI

130 8



ÜRÜN ADI: 8 AKÜLÜK ŞARJ CİHAZI
GİRİŞ VOLTAJI: 220 VOLT AC 50 HZ
GİRİŞ AKIMI: 13 AMPER MAX.
ÇIKIŞ VOLTAJI: 3-116 VOLT DC KADEMELİ
ÇIKIŞ AKIMI: 0-30 AMPER KADEMELİ
GÖSTERGELER: ANALOG AMPERMETRE
GİRİŞ KABLOSU: 3X1.5 MM TRR
ÇIKIŞ KABLOSU: 6 MM NYY 1.5 MT KIRMIZI MAŞALI POZİTİF (+)
ÇIKIŞ KABLOSU: 6 MM NYY 1.5 MT SİYAH MAŞALI NEGATİF (-)
BAĞLANTI ŞEKLİ: SERİ BAĞLANTI
KORUMA / SINIFI: AŞIRI AKIM VE GERİLİM SINIFI 2
ŞARJ KAREKTERİSTİĞİ: I-U AKIM - GERİLİM SOĞUTMA-HAVA SOĞUTMALI
GÜÇ: 3000WATT
EBATLARI: 37 X 51 X 30
AĞIRLIĞI: 35 KG
KULLANIM YERİ: KURŞUN ASİTLİ 45-200AM- PERLİK AKÜ MANUEL ŞARJ EDİLMESİ
GARANTİ SÜRESİ: 3 YIL

225 2



ÜRÜN ADI: 2 AKÜLÜK ŞARJ CİHAZI
GİRİŞ VOLTAJI: 220 VOLT AC 50 HZ
GİRİŞ AKIMI: 2.5 AMPER MAX.
ÇIKIŞ VOLTAJI: 6-30 VOLT DC KADEMELİ
ÇIKIŞ AKIMI: 0-25 AMPER KADEMELİ
GÖSTERGELER: ANALOG AMPERMETRE
GİRİŞ KABLOSU: 3X1.5 MM TRR
ÇIKIŞ KABLOSU: 6 MM NYY 1.5 MT KIRMIZI MAŞALI POZİTİF (+)
ÇIKIŞ KABLOSU: 6 MM NYY 1.5 MT SİYAH MAŞALI NEGATİF (-)
BAĞLANTI ŞEKLİ: SERİ BAĞLANTI
KORUMA / SINIFI: AŞIRI AKIM VE GERİLİM SINIFI 2
ŞARJ KARAKTERİSTİĞİ: I-U AKIM - GERİLİM SOĞUTMA-HAVA SOĞUTMALI
GÜÇ: 600 WATT
EBATLARI: 26 X 31 X 26
AĞIRLIĞI: 12 KG
KULLANIM YERİ: KURŞUN ASİTLİ 45-200AM- PERLİK AKÜ MANUEL ŞARJ EDİLMESİ
GARANTİ SÜRESİ: 3 YIL

S 2418 M



ÜRÜN ADI: 2 AKÜLÜK ŞARJ CİHAZI
GİRİŞ VOLTAJI: 220 VOLT AC 50 HZ
GİRİŞ AKIMI: 1.3 AMPER MAX.
ÇIKIŞ VOLTAJI: 6-12-24 DC KADEMELİ
ÇIKIŞ AKIMI: 0-18 AMPER
GÖSTERGELER: ANALOG AMPERMETRE
GİRİŞ KABLOSU: 3X1.5 MM TRR
ÇIKIŞ KABLOSU: 6 MM NYY 1.5 MT KIRMIZI MAŞALI POZİTİF (+)
ÇIKIŞ KABLOSU: 6 MM NYY 1.5 MT SİYAH MAŞALI NEGATİF (-)
BAĞLANTI ŞEKLİ: DÜZ BAĞLANTI
KORUMA / SINIFI: AŞIRI AKIM VE GERİLİM SINIFI 2
ŞARJ KARAKTERİSTİĞİ: I-U AKIM - GERİLİM SOĞUTMA-HAVA SOĞUTMALI
GÜÇ: 350WATT
EBATLARI: 20 X 28 X 18
AĞIRLIĞI: 5 KG
KULLANIM YERİ: KURŞUN ASİTLİ 45-200AM- PERLİK AKÜ MANUEL ŞARJ EDİLMESİ
GARANTİ SÜRESİ: 2 YIL

AKÜ ŞARJ VE TEST

ÜRÜN ADI: AKÜLÜK TEST CİHAZI
GİRİŞİ VOLTAJİ: 8-36 VOLT DC
GİRİŞ AKIMI: 100 AMPER MAX.
GÖSTERGELER: DİJİTAL 3 HANELİ
VOLTMETRE
GİRİŞ KABLOSU: 7.5 MM NYY 60 CM
KORUMA/SINIFI: AŞIRI AKIM
VE GERİLİM SINIFI 2
TEST KAREKTERİSTİĞİ: I-U
AKIM - GERİLİM
SOĞUTMA: HAVA SOĞUTMALI
GÜÇ: 1200 WATT
EBATLARI: 11X17X17CM
AĞIRLIĞI: 1 KG
KULLANIM YERİ: KURŞUN ASİTLİ
45-100 AMPERLİK
AKÜLERİN TEST EDİLMESİ
GARANTİ SÜRESİ: 2 YIL

110 AKÜ TEST



ÜRÜN ADI: AKÜLÜK TEST CİHAZI
GİRİŞİ VOLTAJİ: 8-36 VOLT DC
GİRİŞ AKIMI: 100-210 AMPER
MAX. KADEMELİ
GÖSTERGELER: DİJİTAL
3 HANELİ VOLTMETRE
GİRİŞ KABLOSU: 16 MM NYY 60 CM
KORUMA/SINIFI: AŞIRI AKIM VE
GERİLİM SINIFI 2
TEST KAREKTERİSTİĞİ: I-U AKIM -
GERİLİM
SOĞUTMA: HAVA SOĞUTMALI
GÜÇ: 2400 WATT
EBATLARI: 15X20X20 CM
AĞIRLIĞI: 1.5 KG
KULLANIM YERİ: KURŞUN ASİTLİ
45-200 AMPERLİK AKÜLERİN
TEST EDİLMESİ
GARANTİ SÜRESİ: 2 YIL

121 AKÜ ŞARJ VE TEST



ÜRÜN ADI: AKÜLÜK TEST CİHAZI
GİRİŞİ VOLTAJİ: 4-36 VOLT DC
GİRİŞ AKIMI: 100-220 AMPER
MAX. KADEMELİ
GÖSTERGELER: DİJİTAL
3 HANELİ VOLTMETRE
GİRİŞ KABLOSU: 16 MM NYY 60 CM
KORUMA / SINIFI: AŞIRI AKIM VE GERİLİM
SINIFI 2
TEST KAREKTERİSTİĞİ: I-U
AKIM - GERİLİM
SOĞUTMA: HAVA SOĞUTMALI
GÜÇ: 2400 WATT
EBATLARI: 15X20X20 CM
AĞIRLIĞI: 1.5 KG
KULLANIM YERİ: KURŞUN ASİTLİ
45-200 AMPERLİK AKÜLERİN
TEST EDİLMESİ
GARANTİ SÜRESİ: 2 YIL

122 AKÜ TEST



ÜRÜN ADI: AKÜLÜK TEST CİHAZI
GİRİŞİ VOLTAJİ: 4-36 VOLT DC
GİRİŞ AKIMI: 100-220 AMPER
MAX. KADEMELİ
GÖSTERGELER: ANALOG VOLTMETRE
GİRİŞ KABLOSU: 16 MM NYY 60 CM
KORUMA / SINIFI: AŞIRI AKIM VE GERİLİM
SINIFI 2
TEST KAREKTERİSTİĞİ: I-U
AKIM - GERİLİM
SOĞUTMA: HAVA SOĞUTMALI
GÜÇ: 2400 WATT
EBATLARI: 15X20X20 CM
AĞIRLIĞI: 1.5 KG
KULLANIM YERİ: KURŞUN ASİTLİ
45-220 AMPERLİK AKÜLERİN
TEST EDİLMESİ
GARANTİ SÜRESİ: 2 YIL

123 ANALOG AKÜ TEST



ÜRÜN ADI: AKÜ ANALİZ TEST CİHAZI
TEST EDİLEN AKÜDEN DC
YÜKVERME AKIMI: 12V DİREK
BESLEME
GİRİŞ KABLOSU: 35MM
GÖSTERGELER: 300 AMPER MAX.
BAĞLANTI GİRİŞİ: DÜZ BAĞLANTI
KORUMA / SINIFI: AŞIRI ISI
SOĞUTMA: HAVA SOĞUTMALI
EBATLARI: 28X18X20 CM
AĞIRLIĞI: 3 KG
GARANTİ SÜRESİ: 2 YIL

1230 A AKÜ ANALİZ



DC12-220V-5A



ÜRÜN ADI: DC GÜÇ KAYNAĞI
GİRİŞİ VOLTAJİ: 220 VOLT AC 50 HZ
GİRİŞ AKIMI: 5 AMPER MAX.
GÖSTERGELER: 3 DİJİT, DİJİTAL
VOLTMETRE AMPERMETRE
GİRİŞ KABLOSU: 35MM NYY 2MT SİYAH
MAŞALI POZİTİF+
KORUMA / SINIFI: AŞIRI AKIM VE GERİLİM
SINIFI 2
SOĞUTMA: HAVA SOĞUTMALI FAN
GÜÇ: 100 WATT
EBATLARI: 32.5X26X22.5CM
AĞIRLIĞI: 5 KG
KULLANIM YERİ: 12 VOLT ARAÇ BEYİN
FORMATLANMASI VE 12V DC GÜÇ
KAYNAK BESLEMESİNİN
GEREKTİĞİ YERLER

DC GÜÇ KAYNAKLARI

DC24-24V-40A



ÜRÜN ADI: DC GÜÇ KAYNAĞI
GİRİŞİ VOLTAJİ: 220 VOLT AC 50 HZ
GİRİŞ AKIMI: 5 MAX.
GÖSTERGELER: 3 DİJİT DİJİTAL
VOLTMETRE AMPERMETRE
GİRİŞ KABLOSU: 35MM NYY 2 MT
SİYAH MAŞALI POZİTİF+
KORUMA / SINIFI: AŞIRI AKIM VE
GERİLİM SINIFI 2
SOĞUTMA: HAVA SOĞUTMALI FAN
GÜÇ: 1000 WATT
EBATLARI: 32.5X26X22.5CM
AĞIRLIĞI: 5 KG
KULLANIM YERİ: 24 VOLT ARAÇ BEYİN
FORMATLANMASI VE 24V DC GÜÇ
KAYNAK BESLEMESİNİN
GEREKTİĞİ YERLER
GARANTİ SÜRESİ: 2 YIL

ATC 12 VOLT



ÜRÜN ADI: ARAÇ TAKVİYE - BEYİN
KORUMA CİHAZI
GİRİŞİ VOLTAJİ: 220 VOLT AC 50 HZ
GİRİŞ AKIMI: 0.3 AMPER MAX.
ÇIKIŞ VOLTAJİ: 12 V DC KADEMELİ
ÇIKIŞ AKIMI: 3400 PEAK AMPER (510 AMPER
10.8 VOLT MAX. TAKVİYE AKIMI)
GÖSTERGELER: DİJİTAL VOLTMETRE
GİRİŞ KABLOSU: 3X0.75 mm TTR 1.5 Mt
ÇIKIŞ KABLOSU: 25 mm² Ø NYY 1.5 MT
KIRMIZI MAŞALI POZİTİF (+)
ÇIKIŞ KABLOSU: 25 mm² Ø NYY 1.5 MT
SİYAH MAŞALI NEGATİF (-)
BAĞLANTI ŞEKLİ: DİREK BAĞLANTI
KORUMA / SINIFI: AŞIRI AKIM VE GERİLİM
SINIFI 2
ŞARJ KARAKTERİSTİĞİ: I-U AKIM -
GERİLİM
SOĞUTMA: HAVA SOĞUTMALI
GÜÇ: 5200 WATT
EBATLARI: 22 X 15X 35
AĞIRLIĞI: 15 KG
KULLANIM YERİ: KURŞUN ASİTLİ
AKÜLERİN TAKVİYE EDİLMESİ
GARANTİ SÜRESİ: 2 YIL

ATC 24 VOLT



ÜRÜN ADI: ARAÇ TAKVİYE - BEYİN
KORUMA CİHAZI
GİRİŞİ VOLTAJİ: 220 VOLT AC 50 HZ
GİRİŞ AKIMI: 1 AMPER MAX.
ÇIKIŞ VOLTAJİ: 13 - 26 V DC KADEMELİ
ÇIKIŞ AKIMI: 3400 PEAK AMPER (510 AMPER
10.8 VOLT MAX. TAKVİYE AKIMI)
GÖSTERGELER: DİJİTAL VOLTMETRE
GİRİŞ KABLOSU: 3X0.75 mm TTR 1.5 Mt
ÇIKIŞ KABLOSU: 25 mm² Ø NYY 1.5 MT
KIRMIZI MAŞALI POZİTİF (+)
ÇIKIŞ KABLOSU: 25 mm² Ø NYY 1.5 MT
SİYAH MAŞALI NEGATİF (-)
BAĞLANTI ŞEKLİ: DİREK BAĞLANTI
KORUMA / SINIFI: AŞIRI AKIM VE GERİLİM
SINIFI 2
ŞARJ KARAKTERİSTİĞİ: I-U AKIM -
GERİLİM
SOĞUTMA: HAVA SOĞUTMALI
GÜÇ: 5200 WATT
EBATLARI: 30 X 30 X 45
AĞIRLIĞI: 22 KG
KULLANIM YERİ: KURŞUN ASİTLİ
AKÜLERİN TAKVİYE EDİLMESİ
GARANTİ SÜRESİ: 2 YIL

ATC 12-24 ATC



ÜRÜN ADI: ARAÇ TAKVİYE - BEYİN
KORUMA CİHAZI
GİRİŞİ VOLTAJİ: 220 VOLT AC 50 HZ
GİRİŞ AKIMI: 0.3 AMPER MAX.
ÇIKIŞ VOLTAJİ: 12 V DC KADEMELİ
ÇIKIŞ AKIMI: 3400 PEAK AMPER (510 AMPER
10.8 VOLT MAX. TAKVİYE AKIMI)
GÖSTERGELER: DİJİTAL VOLTMETRE
GİRİŞ KABLOSU: 3X0.75 mm TTR 1.5 Mt
ÇIKIŞ KABLOSU: 25 mm² Ø NYY 1.5 MT
KIRMIZI MAŞALI POZİTİF (+)
ÇIKIŞ KABLOSU: 25 mm² Ø NYY 1.5 MT
SİYAH MAŞALI NEGATİF (-)
BAĞLANTI ŞEKLİ: DİREK BAĞLANTI
KORUMA / SINIFI: AŞIRI AKIM VE GERİLİM
SINIFI 2
ŞARJ KARAKTERİSTİĞİ: I-U AKIM -
GERİLİM
SOĞUTMA: HAVA SOĞUTMALI
GÜÇ: 5200 WATT
EBATLARI: 22 X 15X 35
AĞIRLIĞI: 15 KG



AKÜ TAKVİYE
KABLOSU



AKÜ TAKVİYE
MAŞASI



AKÜ TAKVİYE
MAŞASI



AKÜ TAKVİYE
KABLOSU



AKÜ BOMESİ
ANTIFRİZ



AKÜ BOMESİ
ANTIFRİZ



ÇANTA KAYNAK MAKİNALARI

ÜRÜN ADI: İNVERTÖR KAYNAK MAKİNESİ
GİRİŞİ VOLTAJİ: 220 VOLT AC 50 HZ
GİRİŞ AKIMI: 18 AMPER MAX.
ÇIKIŞ VOLTAJİ: 38-48 VOLT
ÇIKIŞ AKIMI: 4.4KVA
ELEKTRONİK SINYALI
GÖSTERGELER: ÇALIŞMA SINYALI
GİRİŞ KABLOSU: 3X1.5 mm TTR
ÇIKIŞ KABLOSU: 10 MM NYY
1.5 MT PENSE
ÇIKIŞ KABLOSU: 10 MM NYY
1.5 MT ŞASE
SARGI TİPİ: İNVERTÖR
ALİMYUM PANEL
KORUMA / SINIFI: AŞIRI AKIM VE
GERİLİM SINIFI 2
ŞARJ KAREKTERİSTİĞİ: I-U AKIM - GERİLİM
SOĞUTMA: FANLI HAVA SOĞUTMALI
GÜÇ: 3000 WATT
EBATLARI: 150 X 380 X 230
AĞIRLIĞI: 7 KG
KULLANIM YERİ: TUNİK ÖRTÜLÜ
ELEKTROT KAYNAĞI
GARANTİ SÜRESİ: 2 YIL

200 A INVERTER



ÜRÜN ADI: ARAÇ TAKVIYE - BEYİN
KORUMA CİHAZI
GİRİŞİ VOLTAJİ: 220 V AC ± -1 FAZ (PH)
ŞEBEKEDEN ÇEKİLEN GÜÇ: 4.7kVA @
-E.4kVA @5
FREKANS & ÇEVİRE ORANI: 50 - 60 hz / ~ - @
ÇIKIŞ AKIMI & VOLTAJİ: 170 - 200 A /
25 V DC - 26 V DC
KAYNAK AKIM ARALIĞI: 20 - 200 A
MAKS. AÇIK DEVRE VOLTAJİ: 55 V DC
SİGORTA DEĞER VE TİPİ: 30 A / GECİKMELİ
KORUMA: FAN SOĞUTMA / TERMİK KORUMA
YÜKSÜZ WATT: 40 W
VERİMLİLİK & GÜÇ ETKENİ: / 0.93
YALITIM & KORUMA SINIFI: B / IP21
ÖLÇÜLERİ & AĞIRLIK: 295 x 33 x 14 MM / 6.5 KG
GÜÇ: 3000 WATT
EBATLAR: 150 X 380 X 230
AĞIRLIĞI: 7 KG
KULLANIM YERİ: TUNİK ÖRTÜLÜ
ELEKTROT KAYNAĞI
GARANTİ SÜRESİ: 2 YIL

200 S INVERTER



ÜRÜN ADI: ARK KAYNAK MAKİNESİ
GİRİŞİ VOLTAJİ: 220 VOLT AC 50 HZ
GİRİŞ AKIMI: 15 AMPER MAX.
ÇIKIŞ VOLTAJİ: 20-46 VOLT
ÇIKIŞ AKIMI: 80-250 AMPER
ELEKTRONİK AYARLANABİLİR
GÖSTERGELER ÇIKIŞ SINYALI
GİRİŞ KABLOSU: 3X1.5 MM TRR
KORUMA / SINIFI: AŞIRI AKIM VE
GERİLİM SINIFI 2
SARGI TİPİ: YANMAZ CAM ELYAF
SOĞUTMA: FANLI HAVA SOĞUTMALI
GÜÇ: 2500 WATT
EBATLARI: 22 X 28 X 32
AĞIRLIĞI: 14 KG
KULLANIM YERİ: TUNİK ÖRTÜLÜ
ELEKTROK KAYNAĞI AKU ŞARJ EDİLMESİ
GARANTİ SÜRESİ: 2 YIL

250 EŞ



ÜRÜN ADI: ARK KAYNAK MAKİNESİ
GİRİŞİ VOLTAJİ: 220 VOLT AC 50 HZ
GİRİŞ AKIMI: 18 AMPER MAX.
ÇIKIŞ VOLTAJİ: 42-50 VOLT
ÇIKIŞ AKIMI: 80-250 AMPER KADEMELİ
GÖSTERGELER: ÇALIŞMA SINYALI
GİRİŞ KABLOSU: 3X1.5 MM TRR 1.5 MT
KORUMA / SINIFI: AŞIRI AKIM VE
GERİLİM SINIFI 2
SARGI TİPİ: YANMAZ CAM ELYAF
SOĞUTMA: FANLI HAVA SOĞUTMALI
GÜÇ: 3500 WATT
EBATLARI: 5 X 32 X 40
AĞIRLIĞI: 18 KG
KULLANIM YERİ: TUNİK ÖRTÜLÜ
ELEKTROK KAYNAĞI
GARANTİ SÜRESİ: 2 YIL

250 P ARK



ÜRÜN ADI: ARK KAYNAK MAKİNESİ
GİRİŞİ VOLTAJİ: 220 - 380 VOLT AC 50 HZ
GİRİŞ AKIMI: 32 AMPER MAX.
ÇIKIŞ VOLTAJİ: 38-60 VOLT AC
ÇIKIŞ AKIMI: 80-400 AMPER KADEMELİ
GÖSTERGELER: SINYAL LAMBALARI
GİRİŞ KABLOSU: 3X2.5 TRR 2.5 MT
ÇIKIŞ KABLOSU: 25 MMØ NYY 2 MT PENSE
ÇIKIŞ KABLOSU: 25 MMØ NYY 2 MT ŞASE
KORUMA / SINIFI: AŞIRI AKIM VE
GERİLİM SINIFI 2
SARGI TİPİ: YANMAZ CAM ELYAF
SOĞUTMA: FANLI HAVA SOĞUTMALI
GÜÇ: 8 KVA
EBATLARI: 45 X 70 X 48
AĞIRLIĞI: 62 KG
KULLANIM YERİ: TUNİK ÖRTÜLÜ
ELEKTROK KAYNAĞI
GARANTİ SÜRESİ: 2 YIL

400 AMPER ARK



ÜRÜN ADI: ARK KAYNAK MAKİNESİ
GİRİŞİ VOLTAJİ: 220-380 VOLT AC
GİRİŞ AKIMI: 40 AMPER MAX.
ÇIKIŞ VOLTAJİ: 38-60 VOLT AC
ÇIKIŞ AKIM: 80-500 AMPER KADEMELİ
GÖSTERGELER: SINYAL LAMBALARI
GİRİŞ KABLOSU: 3X2.5 TRR 2.5 MT
ÇIKIŞ KABLOSU: 35 MMØ NYY 2 MT PENSE
ÇIKIŞ KABLOSU: 35 MMØ NYY 2 MT ŞASE
KORUMA / SINIFI: AŞIRI AKIM VE
GERİLİM SINIFI 2
SARGI TİPİ: YANMAZ CAM ELYAF
SOĞUTMA: FANLI HAVA SOĞUTMALI
GÜÇ: 9 KVA
EBATLARI: 45 X 70 X 48
AĞIRLIĞI: 68 KG
KULLANIM YERİ: TUNİK ÖRTÜLÜ
ELEKTROK KAYNAĞI
GARANTİ SÜRESİ: 2 YIL

500 AMPER ARK



ÜRÜN ADI: OTOMATİK ŞARJ CİHAZI
GİRİŞİ VOLTAJİ: 220 VOLT AC 50 HZ
GİRİŞ AKIMI: 7 AMPER MAX.
ÇIKIŞ VOLTAJİ: 110 VOLT DC
ÇIKIŞ AKIMI: 0-10 AMPER ARASINDA
AYARLANABİLİR(SCR KONT.)
GÖSTERGELER3 DİJİTAL VOLTMETRE VE
AMPERMETRE
GİRİŞ KABLOSU: 3X0.1.5 MM TTR
ÇIKIŞ KABLOSU: BORN KLEMENS
BAĞLANTI ŞEKLİ: DÜZ BAĞLANTI
KORUMA / SINIFI: AŞIRI AKIM VE
GERİLİM SINIFI 2
ŞARJ KAREKTERİSTİĞİ: I-U AKIM - GERİLİM
SOĞUTMA: HAVA SOĞUTMALI
GÜÇ: 1200 WATT
EBATLARI: 28 X 30 X 40
AĞIRLIĞI: 16 KG
KULLANIM YERİ:
ŞARJ ÖZELLİĞİ: SABİT SİSTEMLER
İÇİN 110 VOLT
AKÜ 28,8 VOLT SEVİYESİNE GELDİĞİNDE
TAMPON ŞARJA GİRME
GARANTİ SÜRESİ: 2 YIL

11010



ÜRÜN ADI: OTOMATİK ŞARJ CİHAZI
GİRİŞİ VOLTAJİ: 220 VOLT AC 50 HZ
GİRİŞ AKIMI: 1.3 AMPER MAX.
ÇIKIŞ VOLTAJİ: 12 VOLT
ÇIKIŞ AKIMI: 6-15 AMPER KADEMELİ
GÖSTERGELER: ANALOG AMPERMETRE
GİRİŞ KABLOSU: 3X1.5 mm TTR
ÇIKIŞ KABLOSU: 6 mm NYY 1.5 MT KIRMIZI
MAŞALI POZİTİF (+)
ÇIKIŞ KABLOSU: 6 mm NYY 1.5 MT SİYAH
MAŞALI POZİTİF (-)
BAĞLANTI ŞEKLİ: DÜZ BAĞLANTI
KORUMA / SINIFI: AŞIRI AKIM VE
GERİLİM SINIFI 2
ŞARJ KAREKTERİSTİĞİ: I-U AKIM - GERİLİM
SOĞUTMA: HAVA SOĞUTMALI
GÜÇ: 200 VA(180 WATT)
EBATLARI: 24 X 14 X 19
AĞIRLIĞI: 2.2 KG
KULLANIM YERİ: KURŞUN ASİTLİ 45-200
AMPERLIK AKÜ MANÜEL ŞARJ EDİLMESİ
GARANTİ SÜRESİ: 2 YIL

S-1218



İŞ GÜVENLİĞİ



İLK YARDIM
SETİ



TRAFİK KONESİ



ENDESEN
AYARLI BARET



ŞARJLI
EL FENERİ



FOSFORLU
YELEK



YANGIN TÜPÜ
1K



GEZER ÇİZME
KISA



YANGIN TÜPÜ
2K



İMPEKTEKS
YAĞMURLUK



YANGIN TÜPÜ
6K



KALANT
GÖZLÜĞÜ



YANGIN TÜPÜ
12K

DİĞER



KAR ZİNCİRİ



* ÖLÇÜ VE MODELLER İÇİN İRTİBATA GEÇİNİZ